

Liebert
HIROSS



High Performance Air Conditioning

M A T R I X S [017-032]

HIGH PERFORMANCE AIR COOLED CHILLER



SERVICE MANUAL

English

Cod. 272902
Rev. 25.05.2005

Issued by T.D.Service

EMERSON
Network Power



Caution

It is recommended that:

- the manual is retained for the entire service life of the machine;
- the user reads the manual carefully before carrying out any operations on the machine;
- the machine is used exclusively for the purpose for which it is intended; incorrect use of the machine shall release the manufacturer from any liability.

This manual has been prepared to enable the end-user to carry out only those operations that can be done with the panels closed. Any operations that require the opening of doors or equipment panels must be carried out only by qualified personnel.

Each machine is equipped with an electric isolating device which allows the operator to work in conditions of safety. This device must always be used to eliminate risks during maintenance (electric shocks, scalds, automatic restarting, moving parts and remote control).

The panel key supplied with the unit must be kept by the person responsible for maintenance.

For identification of the unit (model and serial no.) in case of the necessity for assistance or spare parts, read the identification labels affixed to the outside and inside of the unit.

IMPORTANT: This manual may be subject to modification; for complete and up-to-date information the user should always consult the manual supplied with the machine.

Index

1 – Introduction	1
1.1 – Foreword	1
1.2 – Responsibility	1
1.3 – Inspection	1
1.4 – General description	1
2 – Preliminary Operations	1
2.1 – Operating limits	1
2.2 – Sound pressure levels	1
2.3 – Transport	2
2.4 – Foundations	2
2.5 – Service area	2
3 – Installation	2
3.1 – Hydraulic connections	2
3.2 – Connection of the safety valve discharge	3
3.3 – Electrical connections	4
4 – Start-Up and Operation	4
4.1 – Initial check	4
4.2 – First start-up (or after a long stop)	5
4.3 – Starting and stopping	5
4.4 – Chillers serving special plants	5
4.5 – Freecooling	5
4.6 – Microprocessor control	5
5 – Refrigerant and Oil Charge	5
5.1 – Refrigerant charge	5
5.2 – Oil charge	5
6 – Safety Devices Settings	6
6.1 – Setting thermostatic expansion valve	6
7 – Maintenance	7
7.1 – Spare parts	7
7.2 – Dismantling the unit	7
8 – Options and Accessories	7
8.1 – Pump set	7
8.2 – Water chiller with partial heat recovery (20%)	7
8.3 – Water chiller with total heat recovery (100%)	8
8.4 – Hydraulic circuit accessories	8
8.5 – Water chiller with inertia tank	8
Tables	9
Drawings	15
Circuits	23

1 – Introduction

1.1 – Foreword

This handbook is aimed at enabling both the installer and the operator to carry out the correct installation, operation and maintenance of the refrigerating machine, without damaging it or causing injuries to the relevant staff.

The handbook is thus an aid for the qualified staff in the arrangement of the specific equipment for the correct installation, operation and maintenance in compliance with the local regulations in force.

The **MATRIX S [017–032]** water chillers can be identified as follows:

CBH023

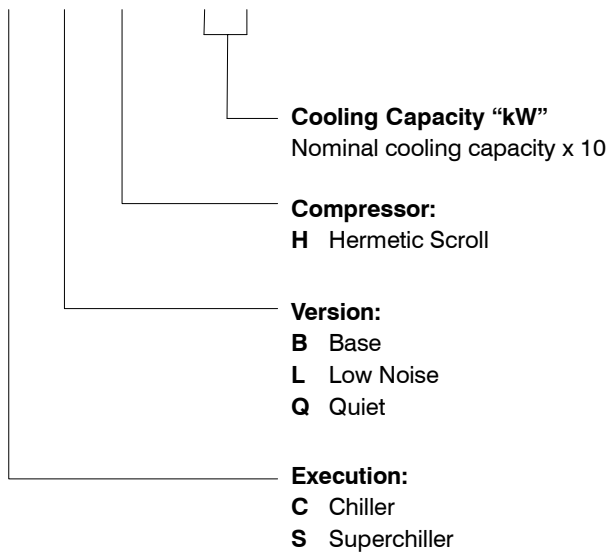

1.2 – Responsibility

Liebert Hiross accepts no present or future responsibility for damage to persons, things or to the machine itself due to operators' negligence, failing to comply with the installation, operation and maintenance instructions of this handbook, failed application of the safety norms in force for the system and the qualified staff charged with the operation and maintenance.

1.3 – Inspection

All units are fully assembled and wired in the manufacturing plant. Before shipment they are charged with the necessary quantities of refrigerant and oil and then tested at the operating conditions normally required by the customer. The machine's hydraulic circuit is equipped with drain plugs and open vent valves; the freecooling coils are supplied dry to avoid possible problems due to frost in the storage period. Immediately inspect the machine carefully on delivery to check for damage during transportation or missing components; possible claims must be made immediately to the carrier and the factory or its representative.

1.4 – General description

MATRIX S units with air cooled condensers have been designed and manufactured for producing chilled water.

They are also available in versions with a built-in freecooling module, in versions with heat recovery for simultaneous heating of thermal circuit water, with a pump assembly installed on the machine and/or inertial buffer tank inside the machine; the chilling units can be equipped with several options indicated in the price list.

The "MATRIX S" product line has been designed utilising the state-of-the-art techniques available nowadays in the indus-

try, and includes all the components necessary for automatic and efficient operation.

Each unit is completely factory assembled; after evacuation, the necessary quantity of refrigerant is added to the refrigerant circuit(s) and the unit is tested.

All the units are equipped with one or two independent refrigerating circuits, each one composed of: an air cooled condenser, a hermetic Scroll compressors and a braze-welded plate evaporator. The components of the liquid line are the charging valves, filters dryers, solenoid valve, shut-off valve, moisture indicator and thermostatic expansion valve.

The hydraulic circuit – with max. working pressure 5 bar – is made up of carbon steel pipes connected with grooved-end (Victaulic) fittings and couplings and include also a flow switch (optional) and, in the freecooling versions, chilled water coils and a three-way valve.

The hermetic scroll compressors are complete with the following protection/safety devices: oil heater, electronic protection monitoring the temperature of the motor windings and the direction of rotation (the latter may be enclosed in the electronics of the compressor or external, depending on the model). The "MATRIX S" water chillers are controlled by the "MICROFACE" microprocessor, managing all the unit operating conditions. The user can change and/or modify the operating parameters through the display keyboard installed on the electrical panel.

The electrical control board is equipped with all the safety and operating devices required for reliable operation. The compressor motors are equipped with protection on all three phases and are started by three-pole contactors.

2 – Preliminary Operations

2.1 – Operating limits

The units can operate within the indicated operating ranges (see Tab. 7). These limits apply to new machines, subject to correct installation and maintenance.

- Ambient air minimum temperature: -25°C for Superchiller, $+15^{\circ}\text{C}$ for Chiller without fan speed control (Operation allowed only in summer mode), -10°C for Chiller with continuous fan speed control (Either Triac or EC fan);
- Maximum outdoor air temperature is in relation to each model, as indicated in Tab. 7. In any case outdoor temperatures aver 45°C are not admitted; such limits are determined by electrical and electronic components fitted on units;
- Maximum water flow allowed: depending on the pressure drop corresponding to the required thermal difference (usually not lower than $3.5^{\circ}\text{C} - 4^{\circ}\text{C}$);
- Minimum allowed water flow: compatible with a sufficient evaporation temperature, to avoid the intervention of the safety devices (to be evaluated for a thermal difference not higher than 8°C);
- Temperature range of the water exiting the evaporator: $4^{\circ}\text{C} - 15^{\circ}\text{C}$;
- Maximum temperature of the water entering the unit: 20°C ; higher temperatures are allowed only at the system start-up and not during normal operation;
- Maximum glycol concentration: 50% (35% with the optional pump assembly installed on the machine);
- Minimum allowed glycol concentration: depending on the minimum temperature of the ambient air expected at the installation site (see Tab. a);
- Maximum pressure of the hydraulic circuit: 5 bar;
- Voltage range for the electric supply: $400\text{ V } \pm 10\%$; max. phase difference: 3%; tolerance on frequency: 1%.

Storage conditions: from -20°C to 45°C for all MATRIX S models

Note:

Avoid positioning in areas with strong dominant winds that may impair the operation and effect the indicated limits.

2.2 – Sound pressure levels

The Tab. 4 shows the noise data for the units in standard configuration (without pumps), operating continuously and measured according to the ISO 3744 norm, in free field conditions. The highest noise levels are detected on the condenser coil side.

Note:

Avoid positioning in areas with possible reverberation of the sound waves, which can adversely effect the noise levels.

2.3 – Transport

- Handle the unit by lifting it with a crane from above;
- The lifting holes are positioned in the frame's base (when lifting, use spreader bars to protect the sides, see Fig. 2).

Note:

Place the lifting tubes in the holes in the base indicated by "LIFT HERE". Lock the ends of the tubes with the locking pins and splits pins as shown in Fig. 2.

The capacity of the lifting gear must be adequate to lift the load in question. Check the weight of the units, the capacity of the lifting gear and ropes and the condition and suitability of the aforementioned equipment.

2.4 – Foundations

- The unit must be placed on a level surface which will support its weight.
- If necessary, position the unit on suitable anti-vibration supports that can be supplied as an option (in rubber or spring-type). Refer to the manual "Installation of the spring anti-vibration supports" for their correct positioning.
- When positioned, level the unit.

Note:

For weight distribution see Fig. 3.

Note:

The weights and their distribution refer to standard units without options; if the pump assembly, or other options are installed on the machine, add the weights of the installed accessories to those of the standard units (see Tab. 8).

2.5 – Service area

- In order to allow free air flow and maintenance of the unit, a minimum area must be left free of obstructions around the unit (see Fig. 1).
- The hot air expelled by the fans must be allowed to rise unimpeded by obstacles for a minimum height of 2.5 m.
- Avoid recirculation of hot air between the suction and discharge, otherwise the unit performance may be impaired or the standard operation can be interrupted.

3 – Installation

3.1 – Hydraulic connections

3.1.1 – Hydraulic circuit construction (Fig. a)

The piping must be connected to the chiller. Construct a chilled water circuit as described below, see Fig. a:

- 1) Place shut-off valves within the circuit to allow servicing;
- 2) Install a pump system suitable for the flow rate required at a pressure head equal to the sum of all the pressure drops (see project data).
Matrix S chillers can be equipped, upon request, with pumps having performance as indicated in Tab. 8;
- 3) Install manometers at the chiller inlet/outlet;
- 4) Install thermometers at the chiller inlet/outlet;
- 5) Connect the pipes to the chiller by flexible joints to avoid transmitting vibrations and to balance the thermal expansion; proceed in the same way even if the pump set is outside the chiller;
- 6) It is useful to include a water pressure switch to give an early warning of low water pressure;

- 7) Place a mesh filter at the inlets of the pump and water chiller (Can be supplied as an optional accessory – Not fitted);
- 8) Install, at the highest points in the circuit, apparatus which allows the bleeding of air and possibly the filling of glycol;
- 9) Place a drain valve at the lowest point in the circuit and immediately at the outlet of the water chiller;
- 10) Install a water filling set including the following:
 - a) filling water meter;
 - b) manometer;
 - c) non-return valve;
 - d) air separator;
 - e) removable supply tube, **which must be disconnected after each charge/top-up**;
- 11) For maximum protection ensure that all tubing exposed to low outdoor temperatures is fitted with anti-freeze heaters and insulated using closed cell synthetic rubber (elastomer);
- 12) The circuit must include an expansion vessel (with safety valve) of suitable capacity;
- 13) Connect the lines avoiding stresses on the machine inner parts.

Note:

If the water chiller is complete with an expansion vessel (supplied as an option), check if the capacity is enough, and install a second vessel in the circuit, if required (see par. 8.4). Follow the indications in Fig. c for the correct sizing.

Note:

The whole circuit must contain a water volume suitable for the capacity of the installed chiller. Check if the inertial capacity given by the sum of the hydraulic volume inside the machine (including the volume of the optional internal tank, if fitted) and the system volume is sufficient, or possibly install a tank in the circuit. Follow the indications in Fig. b for the correct sizing.

Note:

The hydraulic circuit must ensure a constant water supply to the evaporator in every operating condition. Otherwise, the compressors may be damaged by repeated returns of liquid refrigerant on their suction.

Note:

The water flow switch is a compulsory safety component that must be installed and correctly wired to the Matrix S chillers, otherwise the guarantee will be invalidated. It is installed, as standard, on units with the optional on-board pump set, and is available as a option for units without pumps on board: in the latter case the flow switch, if not installed on the machine, can be installed on the hydraulic circuit by the installer, but it is compulsory that it is wired to the electric panel terminal board, as indicated on the wiring diagram.

3.1.2 – Addition of water and ethylene glycol

Very important:

Add water and ethylene glycol to the circuit with a % depending on the minimum temperature of the outside air expected at the installation site. Do not exceed the nominal operating pressure of the circuit's components.

Notes:

- To avoid stratification run the circulation pump for at least 30 minutes after adding any glycol.
- After adding water to the hydraulic circuit **always disconnect the water supply coming from the sanitary supply**; this avoids the danger of glycol entering the sanitary water system.
- After any topping-up of the water check the concentration and add glycol if necessary.

3.1.3 – Water-glycol mixture

Water-glycol mixtures are used as the thermal carrier fluid in very cold climates or with temperatures below zero degrees centigrade. Determine the ethylene glycol % which must be added to the water, with the assistance of Tab. a.

**Tab. a – Ethylene glycol to be added to water
(% in weight of total mixture)**

Ethylene glycol (% in weight)	0	10	20	30	40	50
Freezing temperature, °C (*)	0	-4.4	-9.9	-16.6	-25.2	-37.2
Mixture density at 20°C (*), kg/l	-	1.017	1.033	1.048	1.064	1.080

(*) Values are for Shell antifreeze 402. For different brands, check manufacturer's data.

For the chiller internal water volume refer to Tab. 1. If the optional buffer tank is installed on the machine, add the tank hydraulic volume.

ALWAYS CHARGE THE HYDRAULIC CIRCUIT WITH THE REQUIRED GLYCOL % NECESSARY FOR THE MINIMUM AMBIENT TEMPERATURE AT THE INSTALLATION SITE. FAILING TO COMPLY WITH THIS INSTRUCTION SHALL INVALIDATE THE UNIT WARRANTY.

3.2 – Connection of the safety valve discharge

Safety valves are installed on the high pressure side of the refrigeration circuit: the discharge of these valves must be conveyed outside through a suitable pipe, having a diameter of at least that of the valve outlet, without burdening the valve body. Convey the discharge to areas where the jet cannot harm people and the surrounding environment.

Fig. a – Ideal chilled water circuit

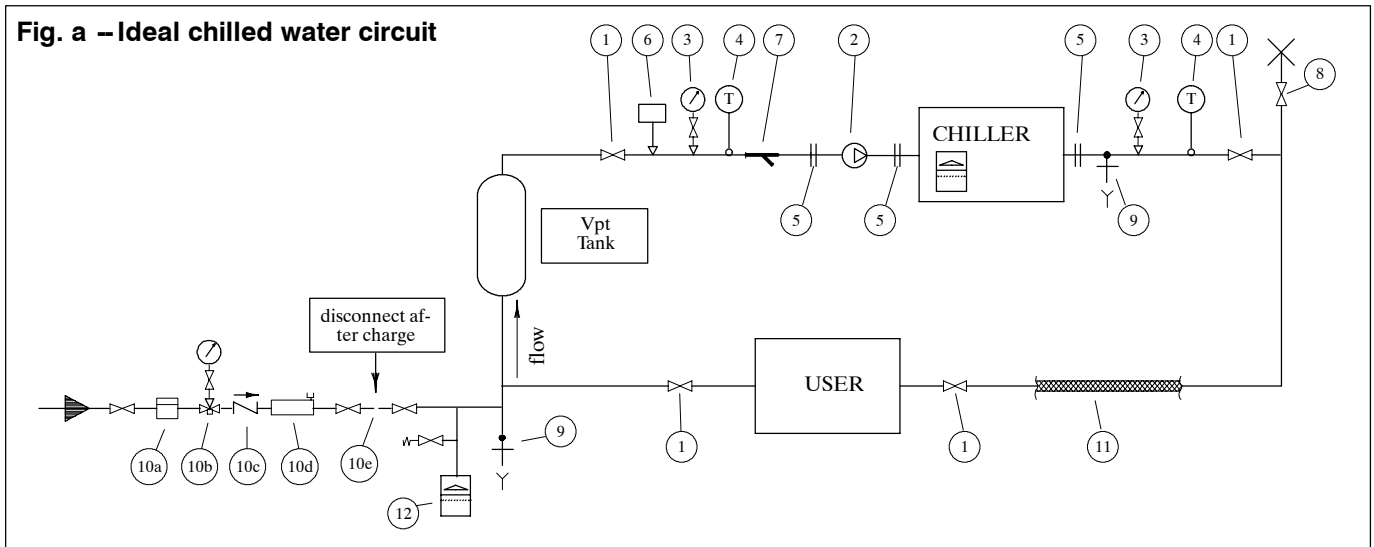

Fig. b – Inertia tank sizing

The total optimum hydraulic volume of the system where the Matrix S chiller is installed can be calculated by the following formula:

$$V = \frac{43 \times Rt}{Xd}$$

where:

- V=minimum required total water volume expressed in litres
- Rt=refrigeration capacity expressed in kW
- Xd=differential band set on the control and expressed in degrees centigrade

Please note that the sum of the hydraulic volume of the Matrix S chiller (Vm) plus the volume of the hydraulic circuit connected to it (Vpc) must be greater than, or equal to the minimum required total water volume (V). If this condition is not satisfied, it is necessary to install an inertia tank (Vpt, as indicated in the Fig. a) with a volume at least equal to the following value: $V_{pt} = V - V_m - V_{pc}$

Fig. c – Sizing of the expansion vessel

The total volume of the expansion vessel is calculated with the following formula:

$$V = \frac{C \times e}{1 - \frac{P_i}{P_f}}$$

where:

- C=quantity of water inside the system expressed in litres
- e=water expansion coefficient, with water at 10°C as a reference
- Pi=absolute pressure of initial charging, equivalent to the vessel pre-charge pressure (typical value 2.5 bara)
- Pf=absolute final tolerated pressure, lower than the operating pressure of the safety valve calibration pressure (typical value 4.0 bara).

Use the values of the water expansion coefficient indicated in the table below:

H ₂ O T [°C]	Density [kg/m ³]	Expansion coefficient "e"
10	999.6	---
20	997.9	0.0017
30	995.6	0.0040
40	992.2	0.0075
50	988.1	0.0116

3.3 – Electrical connections

- 1) Before proceeding with the electrical connections, ensure that:
 - all electrical components are undamaged;
 - all terminal screws are tight;
 - the supply voltage and frequency are in accordance with the rating (with tolerance in accordance with IEC 8–6 norms, March 1990)
 - the allowed phase to phase variability is 3% maximum (see Fig. d). Variability in excess of 3% invalidates the guarantee.
- 2) Supply cable connections (see Tab. 6):
 - Connect the cable to the supply terminals.
 - Use appropriately sized 3–pole cable. An earth wire must also be connected.
 - After having opened the passage in the framework (pre-punched knock-outs) for the supply line entry, restore the original degree of protection using suitable accessories for the wiring and junction boxes.

Operate (open) the main switch before carrying out any maintenance work on electrical components.

Note:

It is forbidden to work on the electrical components without using insulating platforms, and in the presence of water or fog or mist.

Note:

The supply to the external pump assembly must be made before starting the chiller and must be kept on as long as the chiller is in use. Incorrect operation will cause the unit to lock-out because of the internal protections (flow switch intervention).

Note:

The compressors are equipped with an electronic protection device blocking their start if the phase sequence is not correct, or stopping their operation if a thermal relay intervenes. This device is essential for the integrity of the mechanical and electrical components of the compressors. Reset the standard functions by isolating this device and removing the causes of the lock-out.

Note:

The chillers are equipped with their own microprocessor control adjustment. The use of the remote ON–OFF input (located in the electric panel terminal board) as a system temperature control element is forbidden.

Fig. d – Example of calculating phase to phase variability

- 1) The 400 V supply has the following variability:

$$\begin{aligned} RS &= 388 \text{ V} \\ ST &= 401 \text{ V} \\ RT &= 402 \text{ V} \end{aligned}$$

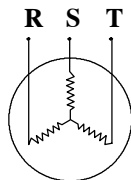

- 2) The average voltage is:

$$\frac{388 + 401 + 402}{3} = 397$$

- 3) The maximum deviation from the average is:

$$402 - 397 = 5 \text{ V}$$

- 4) The phase to phase variability is:

$$\frac{5}{397} \times 100 = 1.26 \text{ (acceptable)}$$

Note:

The power supply should never be disconnected, except when performing maintenance.

4 – Start-Up and Operation

4.1 – Initial check

- 1) Check all water connections.
- 2) Open the shut-off valve on the liquid line.
- 3) Ensure that the intake pressure is higher than 4.0 bar; if this is not the case, prolong pre-heating of the compressor (if possible) and check that the refrigerant shut-off valve is properly sealed, see Fig. 9.
- 4) Open all isolating valves and/or water ball valves.
- 5) In case of climates with temperatures below zero degrees C, make sure the chilled water circuit is filled with the correct concentration of water/glycol.
- 6) Bleed all air out of the chilled water circuit.
- 7) Verify the water flow rate and its direction.
- 8) Ensure that the thermal load is sufficient for start-up.

Caution:

The ambient air temperature probe must be positioned in the shade and protected against the weather.

4.2 – First start–up (or after a long stop)

Operate as follows:

- 1) **At least 8 hours before the start–up, power the crankcase heaters by setting the main isolator switch ON. Make sure the auxiliary circuit has been powered and check the operation (a fault due to an incorrect procedure will invalidate the compressor guarantee).**
- 2) Open the valves of the refrigeration circuit that had been closed before the initial check.
- 3) Check the machinery supplying the thermal load connected with the unit and start the system pump(s).
- 4) **MAKE SURE THE COMPRESSOR OIL HAS BEEN HEATED FOR AT LEAST 8 HOURS;** start the unit only then.
- 5) Make sure the fans rotate in the correct direction (anticlockwise): check the electrical connections, if necessary.
- 6) Make sure the pumps rotate in the correct direction.
- 7) **During the unit start–up an inlet water temperature higher than 20°C is allowed. Under standard operating conditions check that the limits indicated in paragraph 2.1 are not exceeded.**
- 8) Check the correct operation of the control and safety devices.
- 9) Check the outlet temperature of the chilled water (check if the set–point set on the controller is reached).
- 10) Check the oil level in both compressors.
- 11) With the compressors at full load, check there are no bubbles visible in the refrigerant sight glass. If there are any, charge the unit according to par. 5.

4.3 – Starting and stopping

ALWAYS ENSURE THAT THE COMPRESSOR OIL HAS BEEN PREHEATED.

FOR BRIEF STOPPAGES MAINTAIN THE SUPPLY TO THE CRANKCASE HEATER.

- Start the unit setting the Microprocessor switch **ON**.
- Stop the unit setting the Microprocessor switch **OFF**.
- In case of long stops, turn the machine off using the Microprocessor switch **OFF**.
In this case the compressor crankcase heaters remain powered.
- For seasonal shutdown of the unit operate the main switch located on the main electrical power supply. This will disconnect the compressor crankcase heaters.

4.4 – Chillers serving special plants

The units are capable of cooling a water–glycol mixture to temperatures close to 0°C without the need for significant modifications. In the case of modification, the set values of the safety and control components must also be changed. This can be carried out in the factory (at the time of testing) or at the time of installation, only by qualified and authorised personnel.

4.5 – Freecooling

The “freecooling” is a system of pre–cooling and/or cooling the water/glycol mixture using ambient air when the latter is at a temperature below the return mixture temperature. If the outside temperature is sufficiently low to dissipate the entire heat load, the refrigeration compressors automatically switch off, and the mixture’s temperature is controlled by the fan speed adjustment.

If the mixture temperature is too high for freecooling, the compressors will operate as long as necessary to ensure the correct water/glycol mixture temperature.

4.6 – Microprocessor control

Consult the “Microface and Hiromatic” Service Manual.

5 – Refrigerant and Oil Charge

All work on pipes or components of the refrigerating circuit under pressure must be exclusively carried out by qualified staff, competent in such works.

5.1 – Refrigerant charge

WHILST REPAIRING THE REFRIGERATING CIRCUIT RECOVER ALL THE REFRIGERANT IN A CONTAINER: DO NOT ALLOW IT TO ESCAPE. NEVER USE THE COMPRESSOR FOR THE SYSTEM VACUUM (THIS INVALIDATES THE WARRANTY).

- The unit is delivered charged according to the Tab. 5.

Warning for the refrigerant charge:

- Ensure there are no refrigerant leaks.
- Check the refrigerant type in the refrigeration circuit: a unit originally charged by the manufacturer with R407C cannot be charged with R22 and vice versa; possibly apply to the Technical Support Department.
- Charge with the compressor in operation, connecting the cylinder with the charge connector after the thermostatic expansion valve.
Flush the connection pipe between the cylinder and the charging point; tighten the seal joint and then start charging the unit. It is imperative that the cylinder is weighed both before and after the operation.
- For the units with R407C the refrigerant charge must be made exclusively with liquid refrigerant.
- Charge the unit until the bubbles in the sight glass have disappeared and the working conditions of the entire refrigeration circuit have returned to normal (sub–cooling and superheating within the limits indicated below).
- Measure the superheating as follows:
 - 1) Detect the temperature on the suction line, close to the bulb of the thermostatic expansion valve, using a contact thermometer.
 - 2) Connect a pressure gauge (by max. a 30–cm pipe) with the Schraeder connection and read the corresponding saturated evaporating temperature.
 - 3) The superheating is the difference between the two readings.
 - 4) For the units with R407C refer to the pressure gauge scale indicated with the initials D.P. (Dew Point)
- Verify that the superheating is 5°C – 8°C.
- Measure the sub–cooling as follows:
 - 1) Detect the temperature on the liquid line using a contact thermometer.
 - 2) Connect a pressure gauge (by max. a 30–cm pipe) with the Schraeder connection on the liquid line and read the corresponding saturated condensing temperature.
 - 3) The sub–cooling is the difference between the two readings.
 - 4) For the units with R407C refer to the pressure gauge scale indicated with the initials B.P. (Bubble Point)
- Verify that at the condenser outlet, sub–cooling is 3°C – 5°C.

IT IS IMPORTANT TO CARRY OUT CHARGING CORRECTLY. An excess of refrigerant causes an increase in sub–cooling and consequent operating difficulties in the hot season; a shortage of charge generates an increase in superheating and possible compressor stoppages. Whenever work is carried out on the unit, ensure afterwards that the working conditions are correct, checking sub–cooling and superheating.

5.2 – Oil charge

Contact the Technical Support Department for the specifications of the oil to be used for topping up; the oil changes according to the type of used refrigerant.

NEVER MIX DIFFERENT OILS TOGETHER. CLEAN THE PIPING COMPLETELY BEFORE CHANGING THE TYPE OF OIL USED.

TOP-UPS OF UP TO 20–30% OF THE TOTAL AMOUNT OF OIL CONTAINED IN THE COMPRESSOR CRANKCASE ARE PERMITTED; FOR LARGER PERCENTAGES CONTACT THE TECHNICAL SUPPORT DEPARTMENT.

5.2.1 – Procedure for oil topping–up

If there has been any loss of oil then this must be topped up as follows:

- 1) Take a clean, dry, transparent container (with volume calibrations) and fill it with at least twice the amount of oil required.
- 2) Isolate the compressor by closing the cock on the liquid line.

- 3) Connect to the fittings on the compressor body (Schraeder valves) and empty it of refrigerant until atmospheric pressure (1 bar) is reached.
- 4) Using a pipe, connect the oil container to the oil service fitting on the lower part of the compressor.
- 5) Open the oil service cock, lifting the container, so that the oil flows by gravity.
- 6) Charge the required quantity of oil (make sure the tube always remains below the oil level in the container).
- 7) Stop the oil flow by closing the oil service fitting, open the shut–off cock on the refrigerating circuit and restore the drained refrigerant charge.

6 – Safety Devices Settings

The water chiller has already been tested and set up by the manufacturer. The following setting values are suggested in the field.

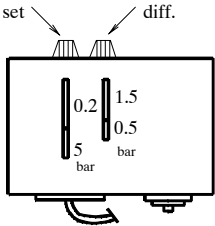
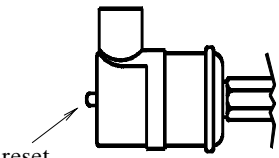
COMPONENT	SETTING	NOTES
Low pressure switch (LP)	Operation with R407C/R22 (standard factory setting): START : 3.6 bar DIFF. : 0.8 bar STOP : 2.8 bar	
High pressure switch (HP)	Operation with R407C/R22 (standard factory setting): STOP : 26 bar START : 20 bar DIFF. : 6 bar (fixed)	

The settings for the safety valves installed on the machine are indicated below:

MODELS	SETTINGS	SAFETY VALVE
CBH/CLH/CQH 017–020–023–025–028 SBH/SLH 017–020–023–025–028 SQH 017–020–023–025	29 bar	high pressure side

6.1 – Setting thermostatic expansion valve

THIS OPERATION MUST BE PERFORMED BY AN EXPERIENCED REFRIGERATION TECHNICIAN.

Before beginning this adjustment be sure that the refrigerant charge is correct, checking the the sub–cooling (3°C – 5°C, as specified in par. 5.1).

The valve has already been factory–set and should be reset when the superheating is not between 5°C – 8°C, as follows:

- 1) Important:
Ensure that the instructions in par. 5.1 have been carried out.
- 2) Allow the compressor to operate for 15 mins.
- 3) Measure the superheating as follows:
 - a) Connect a manometer to the Schraeder connection located on the evaporator outlet tube, and read the manometric temperature on the scale for the refrigerant used (for the units with R407C refer to the pressure gauge scale indicated with the initials D.P. = Dew Point).
 - b) Using a contact thermometer, measure the temperature on the tube coming out of the evaporator, next to the socket used for the manometer.
 - c) The superheating is the difference between the two readings (b – a).
- 4) The superheating must be 5°C – 8°C; if not, set the expansion valve as follows:

- a) Remove the protective cover;
- b) Turn the adjustment screw to return to the optimum values, tightening it in a clockwise direction to increase the superheating, or slackening it to reduce the superheating.
- c) Wait about 10 minutes;
- d) Measure the superheating and repeat the operation if necessary.

N.B:

If the superheating is too low, there is a risk of poor lubrication and consequent breakage of the compressor as a result of pressure shock.

If the superheating is too high the output of the system is limited and the compressor overheats.

7 – Maintenance

The Maintenance Programme below must be carried out by a qualified technician, preferably working under a maintenance contract.

Before any intervention on the unit or accessing the inner components (removing the outer panels), always ensure the machine is switched off. If the front upper panels are removed (coil compartment) wait for the fan(s) to come to a complete stop before accessing the compartment; if the front lower panels are removed, pay special attention when working near the compressor upper part and the discharge line: they are very hot; possibly wait for them to cool. Be very careful when operating close to the finned coils, as the fins are very sharp. Do not remove the fan protection grille before electrically isolating the whole machine. Do not insert foreign matter through the fan protection grille. After the maintenance interventions, always close the unit with the suitable panels, fastened by the tightening system.

Maintenance programme – Monthly check

FANS	<ul style="list-style-type: none"> • Check that the fan motor rotates freely without any abnormal noise, and ensure that the bearings are not running hot. • Also check the current absorption.
CONDENSER AND AIR FILTER	<ul style="list-style-type: none"> • Check the conditions of the filters (if they are supplied); if necessary clean them (including the electrical panel ventilation filter). • Check the condenser coils and clean if necessary with compressed air or soft brushes.
CONTROL	<ul style="list-style-type: none"> • Check that the control equipment, LEDs and display are operating correctly.
ELECTRICAL CIRCUIT	<ul style="list-style-type: none"> • Check the electrical supply on all phases. • Ensure that all electrical connections are tight.
REFRIGERATION CIRCUIT	<ul style="list-style-type: none"> • Check the condensing and the evaporating pressures (to be done by a refrigeration technician). • Check the compressor's current absorption, the delivery temperature and possible unusual noises. • Check the refrigerant charge by means of the sight glass. • Check that the safety devices operate correctly. • Check the correct operation of the thermostatic valve (superheating between 5°C – 8°C). • Check that the oil level indicated by the compressor sight glass is higher than the min. value.
CHILLED WATER CIRCUIT	<ul style="list-style-type: none"> • Ensure that there are no water leaks. • Bleed any air out of the hydraulic circuit using the bleed valves. • Verify that the water flow rate is correct. • Check the inlet – outlet liquid temperature and pressure. • Check the correct operation of the three – way valve (Versions with free – cooling only). • Check if the system is charged with the specified glycol percentage and that no ice has formed in the hydraulic circuit. • Check the evaporator cleanliness.

8 – Options and Accessories

8.1 – Pump set

The centrifugal pump units are direct driven, with close-coupled motors and a single shaft; the induction motor has 2 poles with IP 55 protection and class F insulation.

Pump casings and impellers are in cast iron EN – GJL 200, shafts are in stainless steel, the shaft seal is a unbalanced, mechanical shaft seal with dimensions according to DIN 24 960 and assembly length according to EN 12 756, brass neck ring permits ideal conditions for the use of water mixtures containing ethylene glycol. The pump housing, the motor stool and the motor stator housing are electrocoated.

The pump units have been chosen and sized to operate within specific limits, namely:

- Water / ethylene glycol mixtures up to 65% / 35% by weight;
- Temperatures of the standard pumped fluid not lower than 4°C.

The motor stool forms connection between the pump housing and the motor, and is equipped with a manual air vent screw for venting of the pump housing and the shaft seal chamber. It is very important to carry out this operation as the circulation of liq-

7.1 – Spare parts

The use of original spare parts is recommended.

When placing an order refer to the "Component List" enclosed with the machine and quote the unit model no. and serial no.

7.2 – Dismantling the unit

The machine has been designed and built to ensure continuous operation.

The working life of some of the main components, such as the fans and the compressors, depends on the maintenance that they receive.

If the unit has to be dismantled, the job must be done by skilled refrigeration technicians.

The refrigerant and the lubricating oil in the circuit must be disposed of in conformity with the laws in force in your country.

uid through the duct of the air vent screw ensures lubrication and cooling of the shaft seal.

Between the outlets of the two chambers and the discharge flange, twin-head pumps have a non-return flap valve in EPDM rubber. The flap is opened by the flow of the pumped liquid and cuts off the port of the idle pump chamber.

In the electrical panel there are automatic circuit breakers for each pump; the microprocessor control manages the operating rotation between the two pumps and start-up of the stand-by pump if the primary pump fails.

For the technical features of the pumps and the hydraulic schematic see Tab. 8, Fig. 10 and Fig. 11.

8.2 – Water chiller with partial heat recovery (20%)

This option enables the recovery of up to 20% of the heat normally rejected by the condensers (see Tab. 2). The system does not require any adjustment and is made up of plate heat exchangers installed on each circuit before the condenser. The exchangers are protected by a suitable anti-frost heater that operates when

the system is stopped. It is recommended that a safety valve be installed in the hydraulic circuit to avoid hazards due to overpressures, if there is no water flow through the recuperator.

The water temperature at the recuperator inlet (in stable operating conditions) must be in the range of 25°C – 45°C, with an outlet differential of between 3.5°C – 8°C.

8.3 – Water chiller with total heat recovery (100%)

All heat discharged by the unit to the condenser is recovered (see Tab. 3).

The system includes an additional refrigerating circuit made up of 2 two-way solenoid valves, supplying – in case of hot water demand – a plate exchanger, usually by-passed and sized so as to discharge all condensing heat (also installed before the finned air condenser in series with it); a check valve, a liquid receiver at the exit of the finned air condenser working as storage for the needed additional refrigerant charge (see refrigerating scheme). The recuperator is insulated with closed cell polyurethane and is equipped with heaters activated when the recuperator is deactivated to prevent frost in winter with the system stopped or not perfectly drained.

The operation in total recovery mode is enabled by an external contact. The Microface control will simultaneously suit the fan speed changing the fan speed setpoint differently from the standard operation without recovery (practically slowing the fans down till they switch off); anyway, the operation in recovery mode is enabled also without load at the users. Indeed, if the users do not demand heat, the water flowing to the condenser reaches a temperature that does not enable the total condensation of the compressed gas, and the remaining portion of the phase change can thus take place in finned coil without interrupting the recovery process through the intervention of the machine safety devices.

If the plate exchanger is supplied with too cold water, or if the system is not preset by the installation technician with a three or two-way proportional adjustment valve for the exchanger bypass (indispensable for cold starts, see following “Recommended hydraulic circuit”), the condensing pressure tends to decrease too much; a prolonged condition of low condensing temperature below the safety threshold leads the Microface microprocessor control to disable the heat recovery, protecting the system from any possible malfunctioning.

Fig. e – Recommended hydraulic circuit

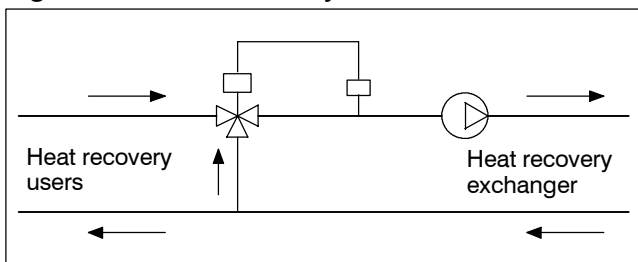

8.4 – Hydraulic circuit accessories

Made up of an expansion vessel (pre-charged at 1.5 bar, max. operating pressure 10 bar) and a safety valve, set at 5 bar. Their position in the hydraulic circuit is illustrated in Fig. 10, Fig. 11.

- Expansion vessel volume: 12 litres for all units.

It is recommended that the total required expansion vessel capacity is always checked, depending on the unit's internal hydraulic volume (with the volume of the buffer tank, if installed), the user circuit volume, the glycol percentage in the mixture, and the expected maximum temperature variation of the mixture.

The water flow switch is a compulsory device protecting the unit. It is installed, as standard, on units with the optional on-board pump set, and is available as a option for units without pumps on board: in the latter case the flow switch, if not installed on the machine, must be installed on the hydraulic circuit by the installer and wired to the electric panel terminal board, as indicated on the wiring diagram.

8.5 – Water chiller with inertia tank

The machine can be supplied complete with a buffer tank; it performs the inertial stabilizer function, for a better compressor operation, summed up in the following two points:

- it reduces the frequency of the compressor start up and consequent high current peaks, which is higher when the system thermal inertia is lower, improving their performance.
- it naturally eliminates the operation troubles caused by sudden load variations (shown by variations of the chilled water temperature).

The buffer tank is supplied complete with manometer and temperature sensor well, air purge valve, discharge valve and sinking connection for electric heaters; max operating pressure: 6 bar. Built in carbon steel and coated with anti-condensate insulation with PVC film proper for outdoor installation. It is installed inside a cabinet which can be supplied either already connected to the unit (mechanically and hydraulically joined to it) or loose (completely separate from the unit).

Technical data:

- Internal volume: 1000 litres
- Net weight: 400 kg
- Working weight: 1400 kg

Tab. 1 – Internal hydraulic volume

Model		Unit volume (*) [l]	Model		Unit volume (*) [l]
CBH	017 – 020	37	SBH	017 – 020	134
	023 – 025	45		023 – 025	164
	028	51		028	170
	030 – 032	60		030 – 032	203
CLH	017 – 020	37	SLH	017 – 020	134
	023 – 025	45		023 – 025	164
	028	51		028	194
	030 – 032	60		030 – 032	166
CQH	017 – 020	37	SQH	017 – 020	156
	023 – 025	45		023 – 025	188
	028	51		028	157
	030	60		030	166

(*) Add the tank's volume for the units with optional buffer tank

Tab. 2 – Partial heat recovery (20%)

Model		017	020	023	025	028	030	032
Heating capacity	kW	40	48	56	62	68	79	86
Water flow	l/s	1.91	2.29	2.68	2.96	3.25	3.77	4.11
Water pressure drop	kPa	15	20	16	19	16	17	20
Water connections	BSP-T				2"			

Working conditions: outdoor temperature 35°C, water inlet/outlet 12/7°C (Chiller versions), glycol mixture 30% inlet/outlet 15/10°C (SuperChiller versions).
Heat recovery conditions: water inlet/outlet 40/45°C.

Tab. 3 – Total heat recovery (100%)

Model		017	020	023	025	028	030	032
Heating capacity	kW	212	238	290	320	357	412	453
Water flow	l/s	10.13	11.37	13.86	15.29	17.06	19.68	21.64
Water pressure drop	kPa	52	65	71	82	83	85	99
Water connections	DN-inch				DN 80 – 3"			

Working conditions: water inlet/outlet 12/7°C (Chiller versions). Heat recovery conditions: water inlet/outlet 40/45°C.

Tab. 4 – Noise levels

The following table indicates the overall sound pressure level at full load conditions, measured 1m from the unit, according to ISO 3774, with an outdoor temperature of 35°C and referred to free field conditions.

Models	Total sound level [dB(A)]	Models	Total sound level [dB(A)]	Models	Total sound level [dB(A)]
CBH/SBH 017-020	73	CLH/SLH 017-020	67	CQH/SQH 017-020	63
CBH/SBH 023-025 CBH/SBH 028	74	CLH/SLH 023-025	68	CQH/SQH 023-025 CQH/SQH 028 CQH/SQH 030	64
CBH/SBH 030-032	75	CLH/SLH 028 CLH/SLH 030-032	69		

Tab. 5 – R 407C refrigerant and oil charge

Models: CBH		017	020	023	025	028	030	032
Refrigerant charge (each circuit)	[kg]	19.5	20.1	28.6	28.7	34.5	42.0	42.1
Oil charge (each circuit)	[lt]	12.4	14.2	16.0	16.0	16.0	16.0	16.0
Models: CLH		017	020	023	025	028	030	032
Refrigerant charge (each circuit)	[kg]	22.5	23.1	32.8	32.9	39.4	42.0	42.1
Oil charge (each circuit)	[lt]	12.4	14.2	16.0	16.0	16.0	16.0	16.0
Models: CQH		017	020	023	025	028	030	
Refrigerant charge (each circuit)	[kg]	23.0	23.6	32.8	32.8	39.4	42.0	
Oil charge (each circuit)	[lt]	12.4	14.2	16.0	16.0	16.0	16.0	
Models: SBH		017	020	023	025	028	030	032
Refrigerant charge (each circuit)	[kg]	19.5	20.1	28.6	28.7	30.3	37.0	37.1
Oil charge (each circuit)	[lt]	12.4	14.2	16.0	16.0	16.0	16.0	16.0
Models: SLH		017	020	023	025	028	030	032
Refrigerant charge (each circuit)	[kg]	19.5	20.1	28.6	28.7	34.4	37.0	37.1
Oil charge (each circuit)	[lt]	12.4	14.2	16.0	16.0	16.0	16.0	16.0
Models: SQH		017	020	023	025	028	030	
Refrigerant charge (each circuit)	[kg]	23.0	23.6	32.8	32.8	34.4	37.0	
Oil charge (each circuit)	[lt]	12.4	14.2	16.0	16.0	16.0	16.0	

Tab. 6 – Electrical characteristics

CBH – R 407C

Size		017	020	023	025	028	030	032
Power supply	–	400 V / 3 Ph / 50 Hz						
OA ⁽¹⁾	A	107	119	138	158	170	188	210
FLA	A	151	181	214	252	290	300	306
LRA	A	291	346	379	453	491	548	554
Compressors power input ⁽¹⁾	kW	54.5	63.6	74.2	85.7	92.5	101.0	116.0
Compressors nominal current ⁽¹⁾	A	96	108	124	144	156	170	192
Compressor max. current	A	35	50	50	69	69	72	72
Fan power input	kW	1.8						
Fan nominal current	A	3.6						
Fan max. current	A	4.0						
Std. head pressure pump model (Opt.)	–	65–190/2		65–230/2		65–260/2		
Std. head pressure pump motor max. power	kW	2.2		3.0		4.0		
Std. head pressure pump max. current	A	4.45		5.95		8.00		
High head pressure pump model (Opt.)	–	65–260/2		65–260/2		65–340/2		
High head pressure pump motor max. power	kW	4.0		4.0		5.5		
High head pressure pump max. current	A	8.00		8.00		11.20		
Electrical cable section (min.)	mm ²	70	95	120	150	185	185	185

(1) Outdoor air temperature 35 °C; water inlet/outlet temperature 12/7 °C

CLH – R 407C

Size		017	020	023	025	028	030	032
Power supply	–	400 V / 3 Ph / 50 Hz						
OA ⁽¹⁾	A	103	115	133	151	165	189	209
FLA	A	147	177	209	247	287	293	299
LRA	A	287	342	374	448	488	541	547
Compressors power input ⁽¹⁾	kW	54.4	63.3	74.0	85.3	90.2	107.0	119.9
Compressors nominal current ⁽¹⁾	A	96	108	124	142	154	178	198
Compressor max. current	A	35	50	50	69	69	72	72
Fan power input	kW	0.95						
Fan nominal current	A	2.2						
Fan max. current	A	2.4						
Std. head pressure pump model (Opt.)	–	65–190/2		65–230/2		65–260/2		
Std. head pressure pump motor max. power	kW	2.2		3.0		4.0		
Std. head pressure pump max. current	A	4.45		5.95		8.00		
High head pressure pump model (Opt.)	–	65–260/2		65–260/2		65–340/2		
High head pressure pump motor max. power	kW	4.0		4.0		5.5		
High head pressure pump max. current	A	8.00		8.00		11.20		
Electrical cable section (min.)	mm ²	70	95	120	150	185	185	185

(1) Outdoor air temperature 35 °C; water inlet/outlet temperature 12/7 °C

CQH – R 407C

Size		017	020	023	025	028	030
Power supply	–	400 V / 3 Ph / 50 Hz					
OA ⁽¹⁾	A	101	111	133	153	169	193
FLA	A	145	175	207	245	283	289
LRA	A	285	340	372	446	484	537
Compressors power input ⁽¹⁾	kW	54.1	62.9	75.5	86.8	96.5	113.1
Compressors nominal current ⁽¹⁾	A	96	106	126	146	162	186
Compressor max. current	A	35	50	50	69	69	72
Fan power input	kW	0.70					
Fan nominal current	A	1.3					
Fan max. current	A	1.5					
Std. head pressure pump model (Opt.)	–	65–190/2		65–230/2		65–260/2	
Std. head pressure pump motor max. power	kW	2.2		3.0		4.0	
Std. head pressure pump max. current	A	4.45		5.95		8.00	
High head pressure pump model (Opt.)	–	65–260/2		65–260/2		65–340/2	
High head pressure pump motor max. power	kW	4.0		4.0		5.5	
High head pressure pump max. current	A	8.00		8.00		11.20	
Electrical cable section (min.)	mm ²	70	95	120	150	185	185

(1) Outdoor air temperature 35 °C; water inlet/outlet temperature 12/7 °C

SBH – R 407C

Size		017	020	023	025	028	030	032
Power supply	–	400 V / 3 Ph / 50 Hz						
OA ⁽¹⁾	A	111	123	145	165	187	203	229
FLA	A	151	181	215	253	291	301	307
LRA	A	291	346	380	454	492	549	555
Compressors power input ⁽¹⁾	kW	57.1	66.3	78.5	90.2	103.8	111.5	128.6
Compressors nominal current ⁽¹⁾	A	100	112	130	150	172	184	210
Compressor max. current	A	35	50	50	69	69	72	72
Fan power input	kW				1.9			
Fan nominal current	A				3.8			
Fan max. current	A				4.0			
Std. head pressure pump model (Opt.)	–	65–260/2		65–340/2			65–410/2	
Std. head pressure pump motor max. power	kW	4.0		5.5			7.5	
Std. head pressure pump max. current	A	8.00		11.20			15.20	
High head pressure pump model (Opt.)	–	65–340/2		65–410/2			65–460/2	
High head pressure pump motor max. power	kW	5.5		7.5			11.0	
High head pressure pump max. current	A	11.20		15.20			21.40	
Electrical cable section (min.)	mm ²	70	95	120	150	185	185	185

(1) Outdoor air temperature 35 °C; 30% glycol water mixture; water inlet/outlet temperature 15/10 °C

SLH – R 407C

Size		017	020	023	025	028	030	032
Power supply	–	400 V / 3 Ph / 50 Hz						
OA ⁽¹⁾	A	111	125	145	165	178	198	222
FLA	A	147	177	209	247	288	294	300
LRA	A	287	342	374	448	489	542	548
Compressors power input ⁽¹⁾	kW	60.3	70.4	82.7	95.6	100.4	112.7	129.4
Compressors nominal current ⁽¹⁾	A	104	118	136	156	166	186	210
Compressor max. current	A	35	50	50	69	69	72	72
Fan power input	kW				1.0			
Fan nominal current	A				2.3			
Fan max. current	A				2.4			
Std. head pressure pump model (Opt.)	–	65–260/2		65–340/2			65–410/2	
Std. head pressure pump motor max. power	kW	4.0		5.5			7.5	
Std. head pressure pump max. current	A	8.00		11.20			15.20	
High head pressure pump model (Opt.)	–	65–340/2		65–410/2			65–460/2	
High head pressure pump motor max. power	kW	5.5		7.5			11.0	
High head pressure pump max. current	A	11.20		15.20			21.40	
Electrical cable section (min.)	mm ²	70	95	120	150	185	185	185

(1) Outdoor air temperature 35 °C; 30% glycol water mixture; water inlet/outlet temperature 15/10 °C

SQH – R 407C

Size		017	020	023	025	028	030
Power supply	–	400 V / 3 Ph / 50 Hz					
OA ⁽¹⁾	A	106	118	141	161	177	205
FLA	A	146	176	207	245	283	289
LRA	A	286	341	372	446	484	537
Compressors power input ⁽¹⁾	kW	57.9	67.3	81.8	94.2	102.5	121.9
Compressors nominal current ⁽¹⁾	A	100	112	134	154	170	198
Compressor max. current	A	35	50	50	69	69	72
Fan power input	kW				0.75		
Fan nominal current	A				1.4		
Fan max. current	A				1.5		
Std. head pressure pump model (Opt.)	–	65–260/2		65–340/2			65–410/2
Std. head pressure pump motor max. power	kW	4.0		5.5			7.5
Std. head pressure pump max. current	A	8.00		11.20			15.20
High head pressure pump model (Opt.)	–	65–340/2		65–410/2			65–460/2
High head pressure pump motor max. power	kW	5.5		7.5			11.0
High head pressure pump max. current	A	11.20		15.20			21.40
Electrical cable section (min.)	mm ²	70	95	120	150	185	185

(1) Outdoor air temperature 35 °C; 30% glycol water mixture; water inlet/outlet temperature 15/10 °C

- Nominal power supply = 400 V; 3 Ph; 50 Hz
- Nominal power supply tolerance = 400 V ± 10 %
- Max. voltage unbalance = 3 %
- The cables have to be sized in compliance with local standards and according to the type and characteristics of installation. Suggested cables section are referred to PVC insulation with a max. working temperature of 70 °C and an ambient temperature of 30 °C.

Tab. 7 – Operating limits

CBH – R 407C

Size		017	020	023	025	028	030	032
Working Range								
Max. outdoor air temperature ⁽¹⁾	°C	45.0	41.5	45.0	43.0	44.0	45.0	43.5
Safety Device Settings								
High pressure switch ⁽¹⁾	Barg	26.0						
High pressure safety valve	Barg	29.0						
Low pressure switch	Barg	2.8						

⁽¹⁾ With nominal air flow; water flow outlet at 7 °C; full load

CLH – R 407C

Size		017	020	023	025	028	030	032
Working Range								
Max. outdoor air temperature ⁽¹⁾	°C	45.0	41.5	45.0	43.0	45.0	42.0	41.5
Safety Device Settings								
High pressure switch ⁽¹⁾	Barg	26.0						
High pressure safety valve	Barg	29.0						
Low pressure switch	Barg	2.8						

⁽¹⁾ With nominal air flow; water flow outlet at 7 °C; full load

CQH – R 407C

Size		017	020	023	025	028	030
Working Range							
Max. outdoor air temperature ⁽¹⁾	°C	45.0	41.5	44.0	42.0	41.5	39.5
Safety Device Settings							
High pressure switch ⁽¹⁾	Barg	26.0					
High pressure safety valve	Barg	29.0					
Low pressure switch	Barg	2.8					

⁽¹⁾ With nominal air flow; water flow outlet at 7 °C; full load

SBH – R 407C

Size		017	020	023	025	028	030	032
Working Range								
Max. outdoor air temperature ⁽²⁾	°C	42.5	39.5	42.5	40.5	38.5	41.0	39.0
Safety Device Settings								
High pressure switch ⁽²⁾	Barg	26.0						
High pressure safety valve	Barg	29.0						
Low pressure switch	Barg	2.8						

⁽²⁾ With nominal air flow; mixture flow outlet at 10 °C; full load

SLH – R 407C

Size		017	020	023	025	028	030	032
Working Range								
Max. outdoor air temperature ⁽²⁾	°C	40.0	37.0	39.5	37.5	40.0	40.0	38.5
Safety Device Settings								
High pressure switch ⁽²⁾	Barg	26.0						
High pressure safety valve	Barg	29.0						
Low pressure switch	Barg	2.8						

⁽²⁾ With nominal air flow; mixture flow outlet at 10 °C; full load

SQH – R 407C

Size		017	020	023	025	028	030
Working Range							
Max. outdoor air temperature ⁽²⁾	°C	42.0	39.0	40.5	38.5	39.0	36.5
Safety Device Settings							
High pressure switch ⁽²⁾	Barg	26.0					
High pressure safety valve	Barg	29.0					
Low pressure switch	Barg	2.8					

⁽²⁾ With nominal air flow; mixture flow outlet at 10 °C; full load

Tab. 8 – Pump set characteristics (opt.)

2 pole pump set, standard head pressure (data refers to each pump)

Models			017	020	023	025	028	030	032
CBH	Water flow	m ³ /h	26.88	29.22	36.76	39.56	44.86	55.16	57.02
	Available head pressure	kPa	119	107	130	116	141	91	55
CLH	Water flow	m ³ /h	26.92	29.32	36.81	39.69	45.48	51.35	55.83
	Available head pressure	kPa	119	107	130	114	139	105	67
CQH	Water flow	m ³ /h	27.01	29.39	36.38	39.19	43.67	49.55	–
	Available head pressure	kPa	119	106	133	117	149	119	–
Pump quantity		Nr.	1/2	1/2	1/2	1/2	1/2	1/2	1/2
Pump rotor model		–	65–190/2		65–230/2		65–260/2		
Nominal motor power		kW	2.2	2.2	3.0	3.0	4.0	4.0	4.0
Noise level (*)		dB(A)	60	60	59	59	63	63	63
Pump weight		kg	57.9/116.4		69.3/139.2		74.3/149.2		

2 pole pump set, high head pressure (data refers to each pump)

Models			017	020	023	025	028	030	032
CBH	Water flow	m ³ /h	26.88	29.22	36.76	39.56	44.86	53.16	57.02
	Available head pressure	kPa	197	187	176	165	227	188	159
CLH	Water flow	m ³ /h	26.92	29.32	36.81	39.69	45.48	51.35	55.83
	Available head pressure	kPa	197	186	176	162	224	199	169
CQH	Water flow	m ³ /h	27.01	29.39	36.38	39.19	43.67	49.55	–
	Available head pressure	kPa	197	186	179	166	232	210	–
Pump quantity		Nr.	1/2	1/2	1/2	1/2	1/2	1/2	1/2
Pump rotor model		–	65–260/2				65–340/2		
Nominal motor power		kW	4.0	4.0	4.0	4.0	5.5	5.5	5.5
Noise level (*)		dB(A)	63	63	63	63	63	63	63
Pump weight		kg	74.3/149.2				89.2/178.9		

2 pole pump set, standard head pressure (data refers to each pump)

Models			017	020	023	025	028	030	032
SBH	30% glycol/water mixture flow	m ³ /h	31.91	34.52	43.66	46.77	51.05	62.43	66.46
	Available head pressure	kPa	107	83	131	101	86	75	25
SLH	30% glycol/water mixture flow	m ³ /h	30.71	33.14	42.18	45.06	52.22	62.00	66.16
	Available head pressure	kPa	117	95	144	118	61	102	54
SQH	30% glycol/water mixture flow	m ³ /h	31.58	34.21	42.52	45.60	51.46	57.51	–
	Available head pressure	kPa	127	107	132	103	101	147	–
Pump quantity		Nr.	1/2	1/2	1/2	1/2	1/2	1/2	1/2
Pump rotor model		–	65–260/2		65–340/2		65–410/2		
Nominal motor power		kW	4.0	4.0	5.5	5.5	5.5	7.5	7.5
Noise level (*)		dB(A)	63	63	63	63	63	68	68
Pump weight		kg	74.3/149.2		89.2/178.9		91.1/182.7		

2 pole pump set, high head pressure (data refers to each pump)

Models			017	020	023	025	028	030	032
SBH	30% glycol/water mixture flow	m ³ /h	31.91	34.52	43.66	46.77	51.05	62.43	66.46
	Available head pressure	kPa	187	165	223	195	174	139	95
SLH	30% glycol/water mixture flow	m ³ /h	30.71	33.14	42.18	45.06	52.22	62.00	66.16
	Available head pressure	kPa	197	176	234	211	150	166	123
SQH	30% glycol/water mixture flow	m ³ /h	31.58	34.21	42.52	45.60	51.46	57.51	–
	Available head pressure	kPa	207	189	223	196	188	206	–
Pump quantity		Nr.	1/2	1/2	1/2	1/2	1/2	1/2	1/2
Pump rotor model		–	65–340/2		65–410/2		65–460/2		
Nominal motor power		kW	5.5	5.5	7.5	7.5	7.5	11.0	11.0
Noise level (*)		dB(A)	63	63	68	68	68	65	65
Pump weight		kg	89.2/178.9		91.1/182.7		149.4/306.4		

(*) According to ISO 3744

Fig. 1 – Service areas (top view)

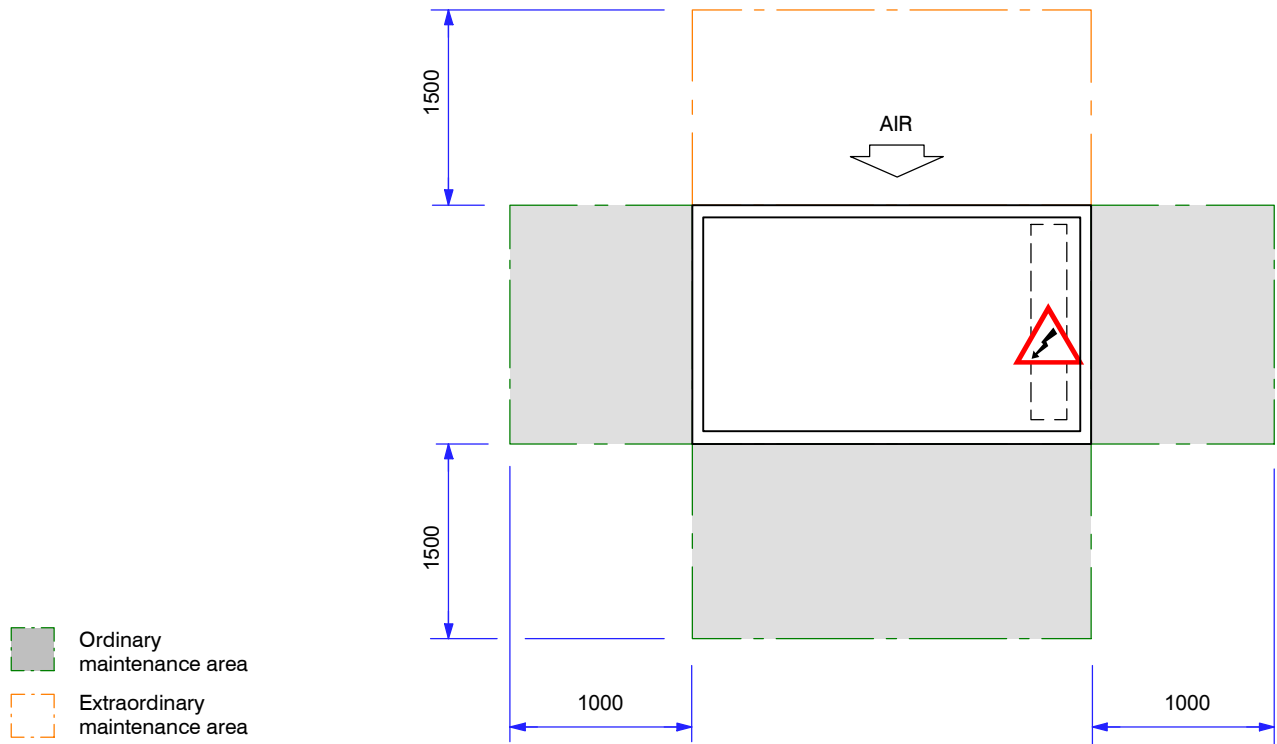

Notes:

Minimum distance between 2 units from condensing coil side = 3 m
Do not obstruct the air exiting the fans for a minimum distance of 2.5 m

Fig. 2 – Lifting instructions with tubes

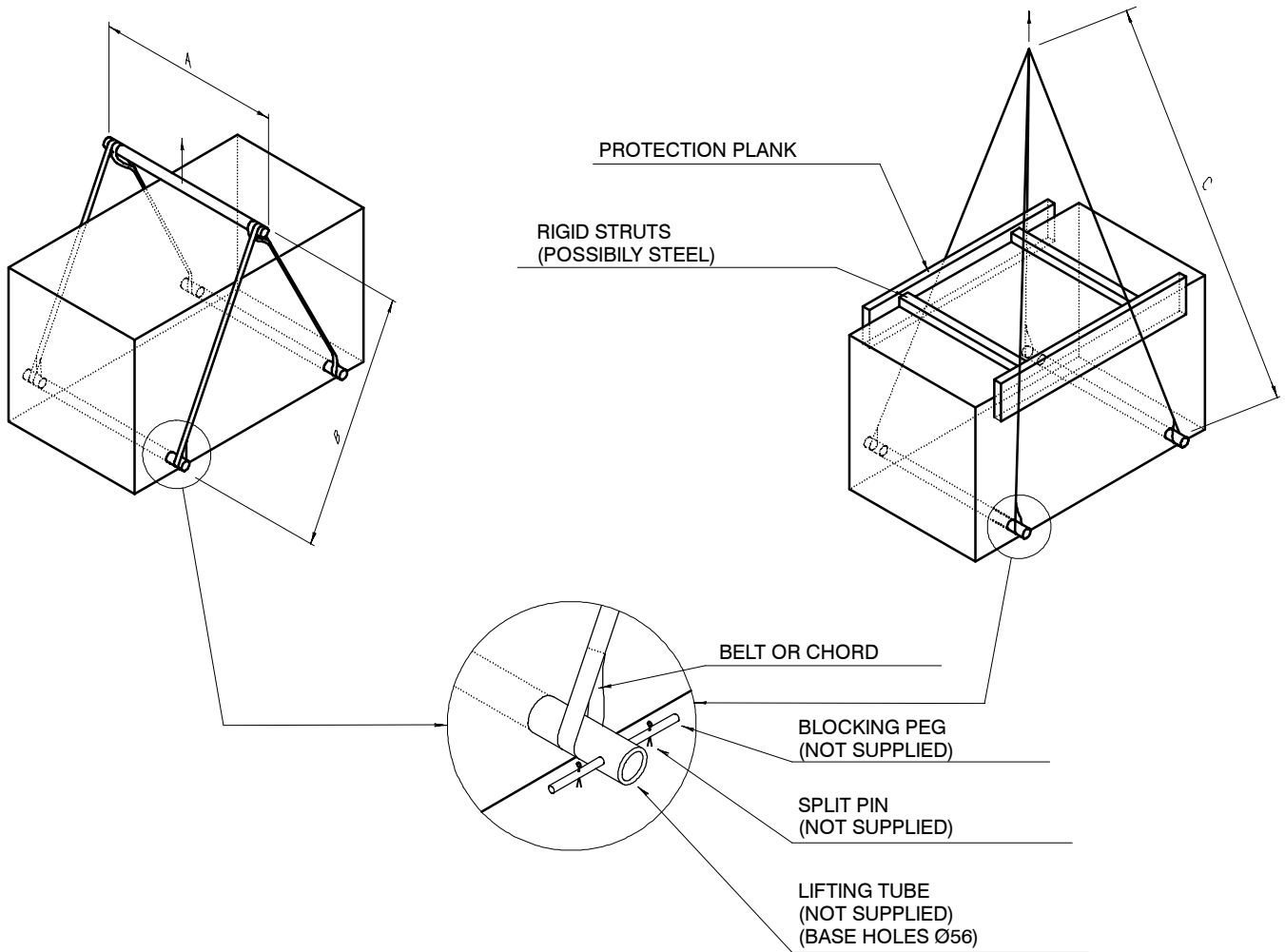

N.B: Place the lifting tubes in the holes in the base indicated by the words “LIFT HERE”. Lock the ends of the tubes in position with the locking pins and split pins as shown above. The capacity of the lifting gear must be adequate to lift the load in question. Check the weight of the unit, the capacity of the lifting gear and ropes and the condition and suitability of the aforementioned equipment. Lift the unit with a speed suitable for the load to be moved, so as not to damage the structure.

Lifting

Models	“A” (m)	“B” (m)	“C” (m)
CBH / CLH 017 – 020 – 023 – 025 – 028 – 030 – 032	1.8	≈ 5.0	≈ 9.0
CQH 017 – 020 – 023 – 025 – 028 – 030			
SBH / SLH 017 – 020 – 023 – 025 – 028 – 030 – 032			
SQH 017 – 020 – 023 – 025 – 028 – 030			

Fig. 3 – Support positions and loads

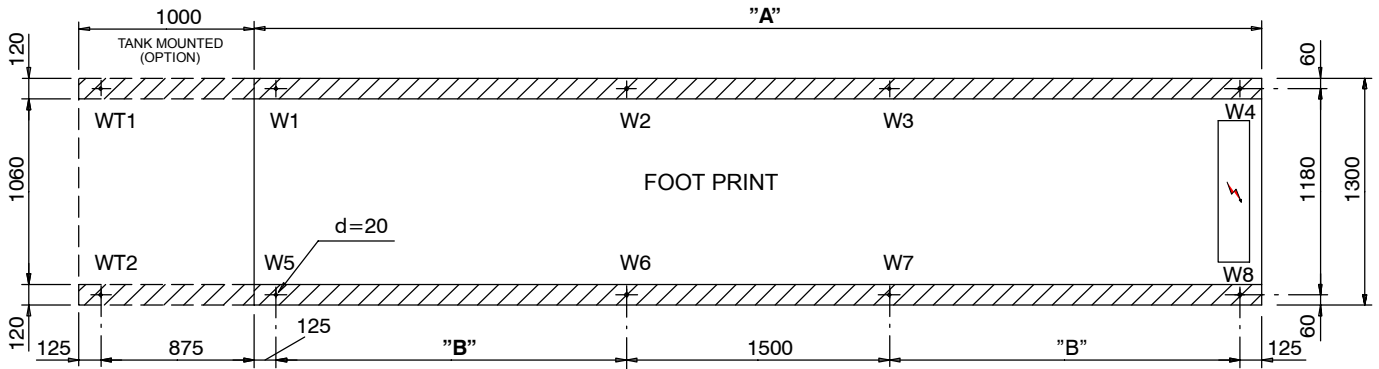

Tank
(supply not mounted on unit)

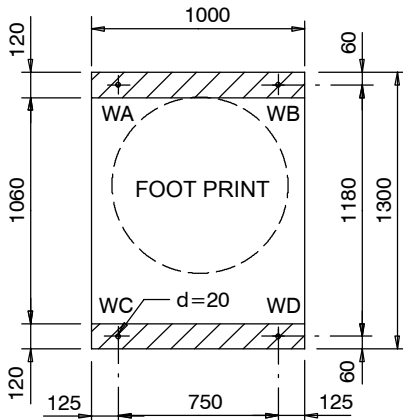

WA = WB = 406 kg
WC = WD = 299 kg

Dimensions

Dimensions (mm)		"A"	"B"
Model	Size		
CBH-SBH CLH-SLH	017 - 020	3750	1000
CBH-SBH CLH-SLH CQH-SQH	023 - 025 - 028 023 - 025 017 - 020	4750	1500
CBH-SBH CLH-SLH CQH-SQH	030 - 032 028 - 030 - 032 023 - 025 - 028 - 030	5750	2000

Weight distribution without tank

Weight Distribution (kg)		W 1	W 2	W 3	W 4	W 5	W 6	W 7	W 8
Model	Size								
CBH	017	170	170	206	206	234	234	284	284
	020	177	177	223	223	247	247	311	311
	023	206	206	292	292	276	276	391	391
	025	206	206	292	292	276	276	391	391
	028	225	225	306	306	290	290	394	394
	030	257	257	364	364	324	324	459	459
	032	257	257	375	375	326	326	476	476
CLH	017	183	183	222	222	240	240	291	291
	020	189	189	239	239	253	253	319	319
	023	220	220	313	313	282	282	400	400
	025	220	220	313	313	282	282	400	400
	028	248	248	363	363	305	305	448	448
	030	257	257	369	369	325	325	467	467
	032	256	256	379	379	328	328	485	485
CQH	017	193	193	258	258	251	251	336	336
	020	196	196	279	279	259	259	368	368
	023	225	225	346	346	290	290	445	445
	025	225	225	346	346	290	290	445	445
	028	248	248	363	363	305	305	448	448
	030	256	256	376	376	327	327	480	480
SBH	017	232	232	263	263	265	265	300	300
	020	238	238	280	280	278	278	327	327
	023	279	279	370	370	310	310	412	412
	025	279	279	370	370	310	310	412	412
	028	284	284	369	369	319	319	415	415
	030	326	326	440	440	357	357	481	481
	032	325	325	450	450	360	360	498	498
SLH	017	233	233	266	266	268	268	306	306
	020	239	239	284	284	281	281	333	333
	023	279	279	374	374	313	313	419	419
	025	279	279	374	374	313	313	419	419
	028	317	317	436	436	341	341	469	469
	030	304	304	420	420	351	351	485	485
	032	304	304	431	431	354	354	502	502
SQH	017	267	267	333	333	286	286	357	357
	020	269	269	354	354	295	295	388	388
	023	312	312	438	438	332	332	466	466
	025	312	312	438	438	332	332	466	466
	028	295	295	420	420	336	336	477	477
	030	304	304	427	427	353	353	497	497

Weight Distribution with tank

Weight Distribution (kg)		WT1	W 1	W 2	W 3	W 4	WT2	W 5	W 6	W 7	W 8
Model	Size										
CBH	017	431	431	233	233	233	451	451	244	244	244
	020	428	428	251	251	251	456	456	268	268	268
	023	432	432	315	315	315	462	462	337	337	337
	025	432	432	315	315	315	462	462	337	337	337
	028	444	444	328	328	328	467	467	345	345	345
	030	455	455	382	382	382	479	479	402	402	402
	032	450	450	391	391	391	479	479	416	416	416
CLH	017	439	439	248	248	248	450	450	254	254	254
	020	436	436	265	265	265	455	455	277	277	277
	023	440	440	332	332	332	460	460	347	347	347
	025	440	440	332	332	332	460	460	347	347	347
	028	451	451	377	377	377	467	467	390	390	390
	030	453	453	386	386	386	479	479	408	408	408
	032	448	448	395	395	395	479	479	422	422	422
CQH	017	436	436	280	280	280	452	452	290	290	290
	020	430	430	300	300	300	453	453	315	315	315
	023	436	436	360	360	360	462	462	382	382	382
	025	436	436	360	360	360	462	462	382	382	382
	028	451	451	377	377	377	467	467	390	390	390
	030	449	449	392	392	392	479	479	418	418	418
	032	449	449	392	392	392	479	479	418	418	418
SBH	017	472	472	286	286	286	453	453	274	274	274
	020	469	469	304	304	304	459	459	297	297	297
	023	478	478	384	384	384	463	463	372	372	372
	025	478	478	384	384	384	463	463	372	372	372
	028	481	481	385	385	385	469	469	376	376	376
	030	497	497	450	450	450	482	482	436	436	436
	032	492	492	459	459	459	482	482	450	450	450
SLH	017	471	471	289	289	289	455	455	279	279	279
	020	468	468	307	307	307	460	460	303	303	303
	023	476	476	388	388	388	464	464	378	378	378
	025	476	476	388	388	388	464	464	378	378	378
	028	494	494	444	444	444	472	472	424	424	424
	030	481	481	433	433	433	483	483	435	435	435
	032	477	477	442	442	442	483	483	448	448	448
SQH	017	484	484	348	348	348	454	454	326	326	326
	020	478	478	368	368	368	456	456	351	351	351
	023	491	491	443	443	443	466	466	421	421	421
	025	491	491	443	443	443	466	466	421	421	421
	028	477	477	429	429	429	474	474	426	426	426
	030	478	478	439	439	439	484	484	444	444	444
	032	478	478	439	439	439	484	484	444	444	444

Fig. 4 – Rubber anti-vibration support + 1000 liters tank

Rubber support dimensions

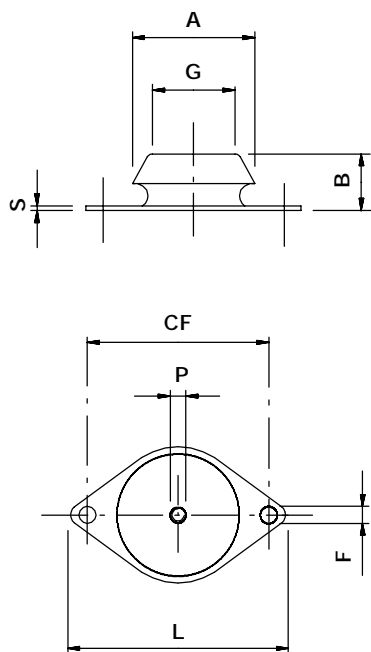

Rubber support installation

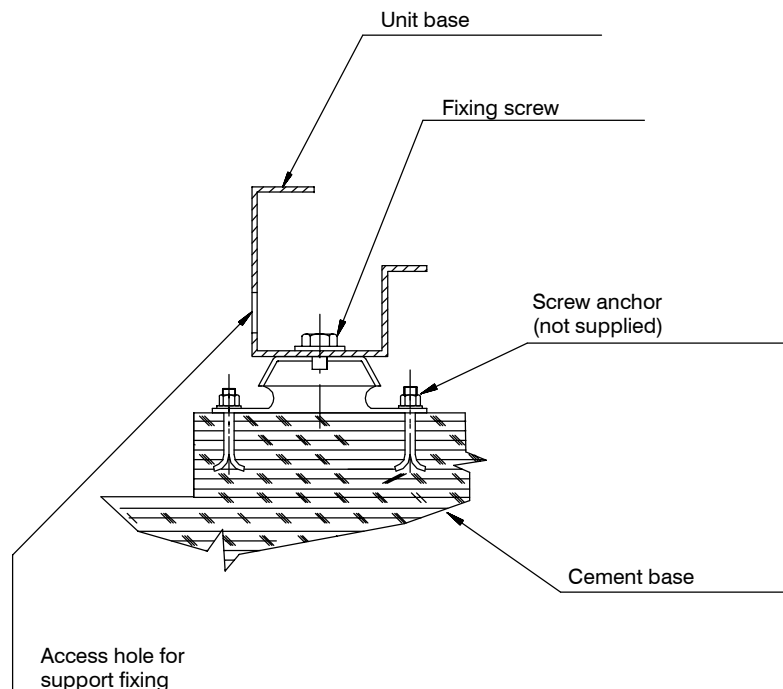

Single support code

Code	A (mm)	B (mm)	P (mm)	F (mm)	CF (mm)	G (mm)	L (mm)	S (mm)
270327	82	35	M10	11.0	110	60	128	2
270326	108	50	M16	16.5	160	83	190	5

Rubber supports + 1000 liters tank

Unit	Configuration	Support kit code	Single support code	Kit support pieces
CBH – CLH – CQH 017-020-023-025-028-030-032	Without tank	485625	270326	8
SBH – SLH – SQH 017-020-023-025-028-030-032				
CBH – CLH – CQH 017-020-023-025-028-030-032	With tank	485626	270326	10
SBH – SLH – SQH 017-020-023-025-028-030-032				
1000 liters tank	Loose supplied	485620	270327	4

Each kit is complete with stainless steel fixing screws and plain washers for unit assembly.

Fig. 5 – Overall dimensions (without tank)

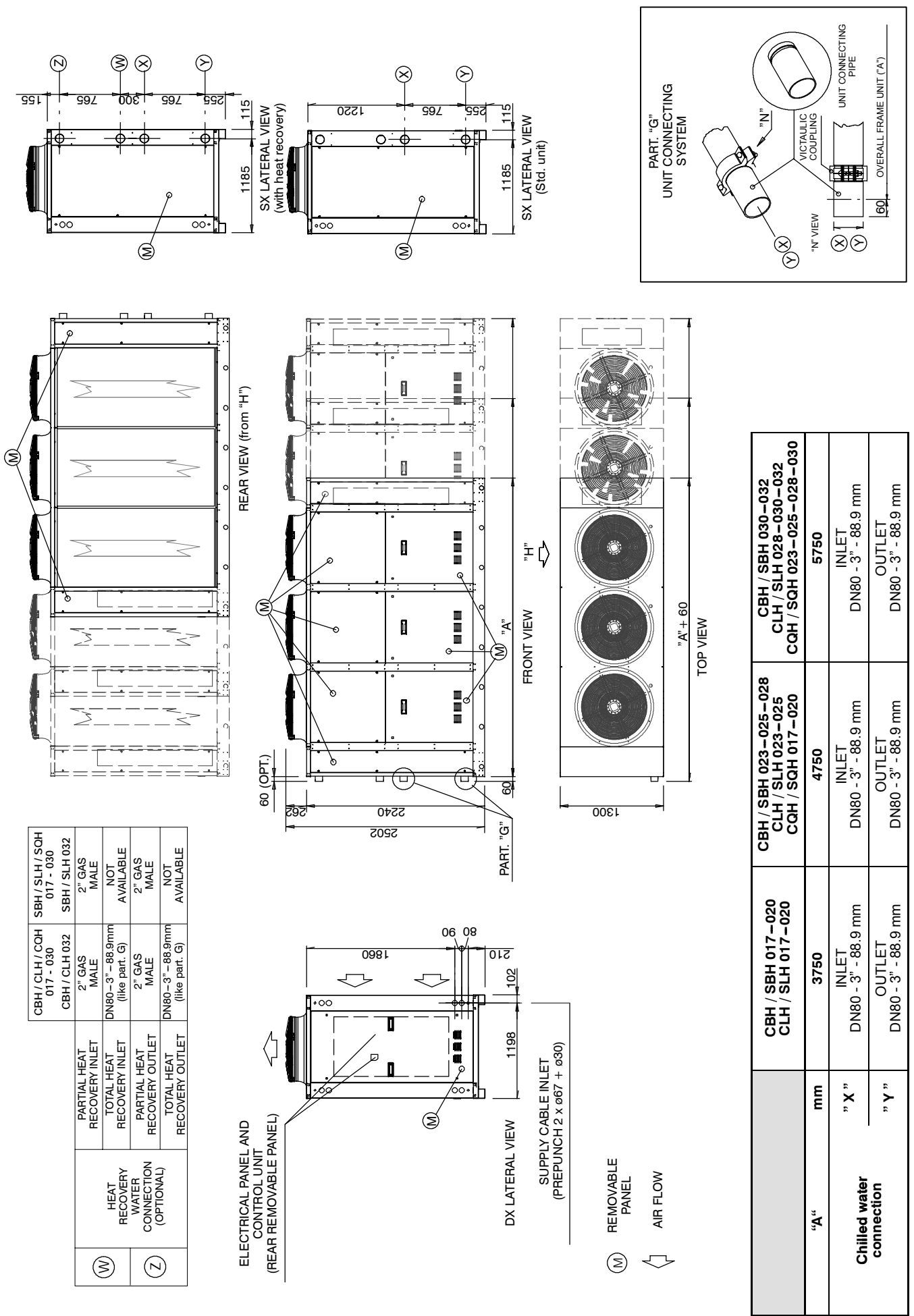

	CBH / SBH 017-020 CLH / SLH 017-020	3750	INLET DN80 - 3" - 88.9 mm	OUTLET DN80 - 3" - 88.9 mm
"A"	mm	3750	INLET DN80 - 3" - 88.9 mm	OUTLET DN80 - 3" - 88.9 mm
Chilled water connection	"X"	mm	INLET DN80 - 3" - 88.9 mm	OUTLET DN80 - 3" - 88.9 mm
	"Y"	mm	INLET DN80 - 3" - 88.9 mm	OUTLET DN80 - 3" - 88.9 mm

Fig. 6 – Overall dimensions (with tank)

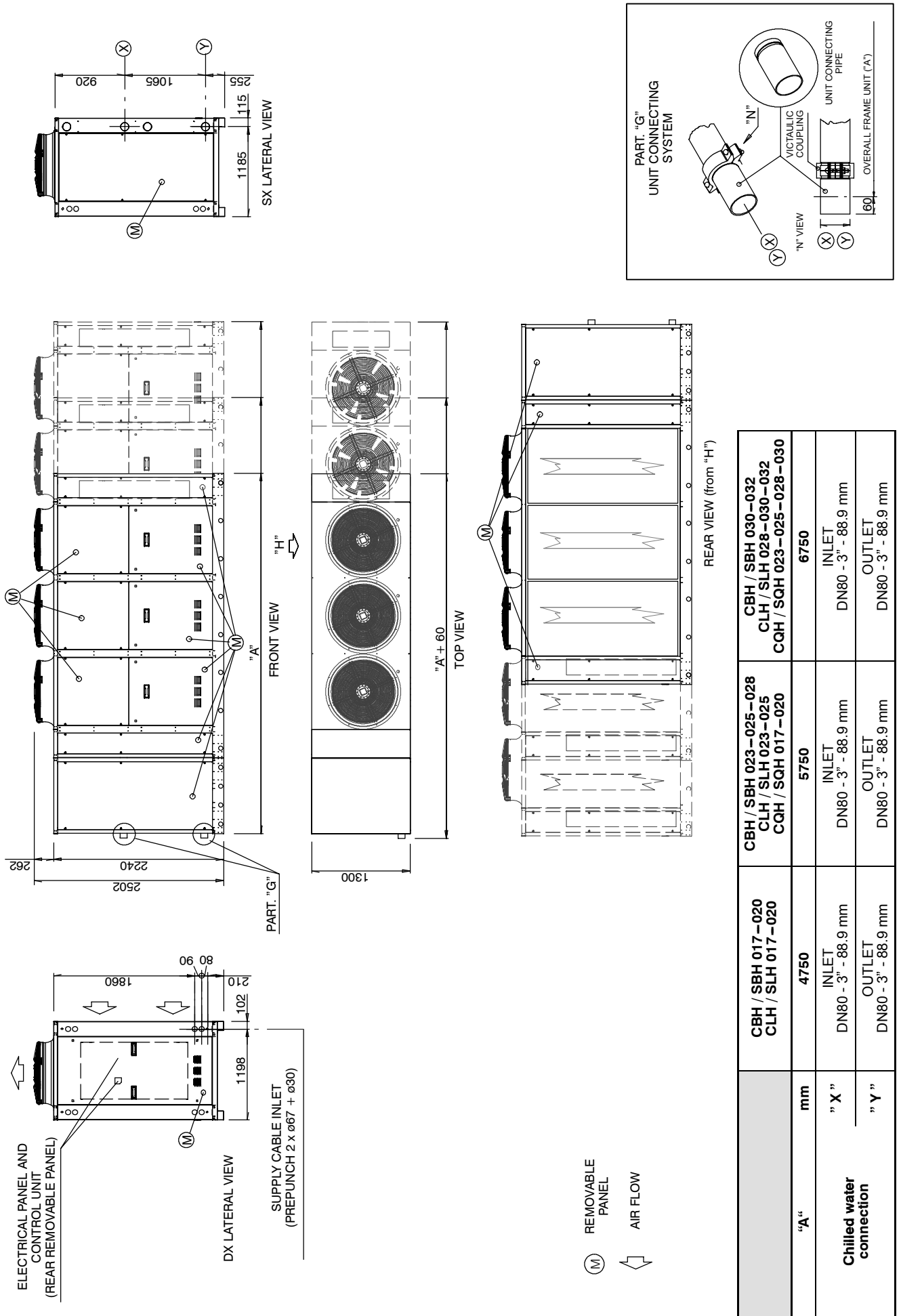
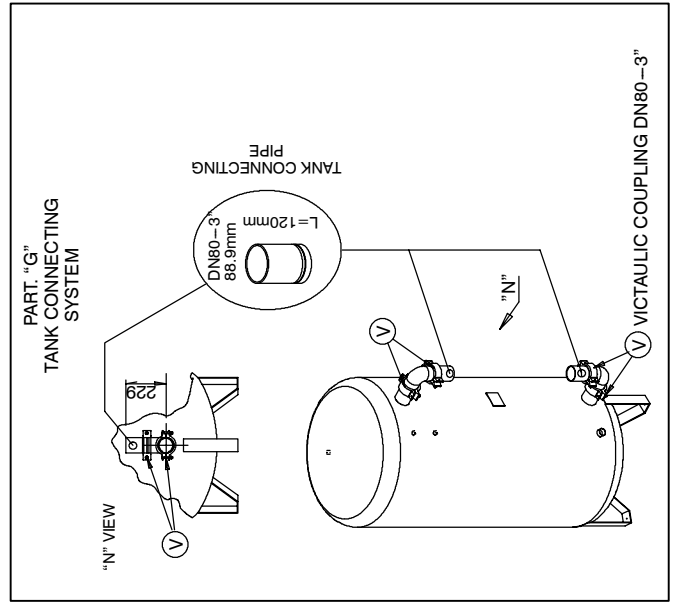
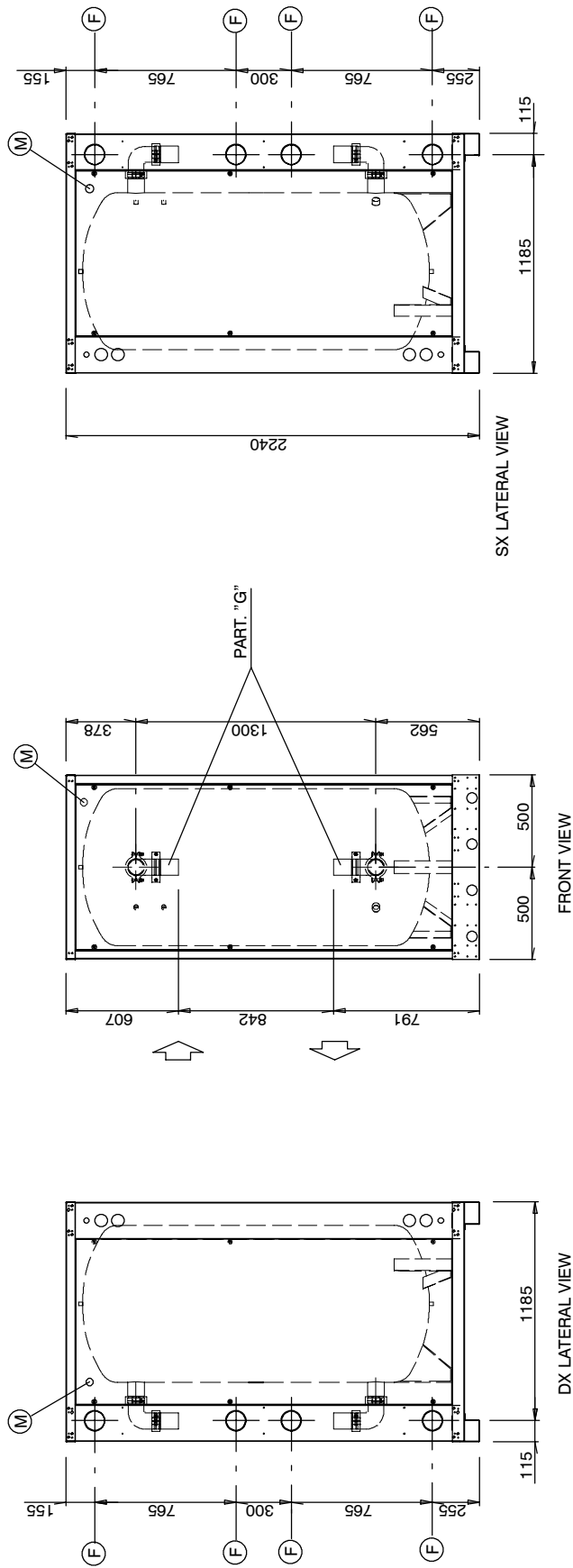

Fig. 7 – Tank Overall Dimensions (supply not mounted on unit)



- (M) REMOVABLE PANEL
- (E) PREPUNCHED $\phi 110$ (for inlet/outlet pipes connections)

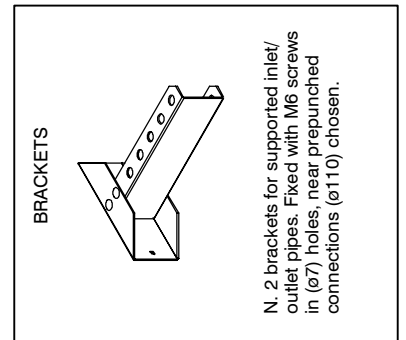
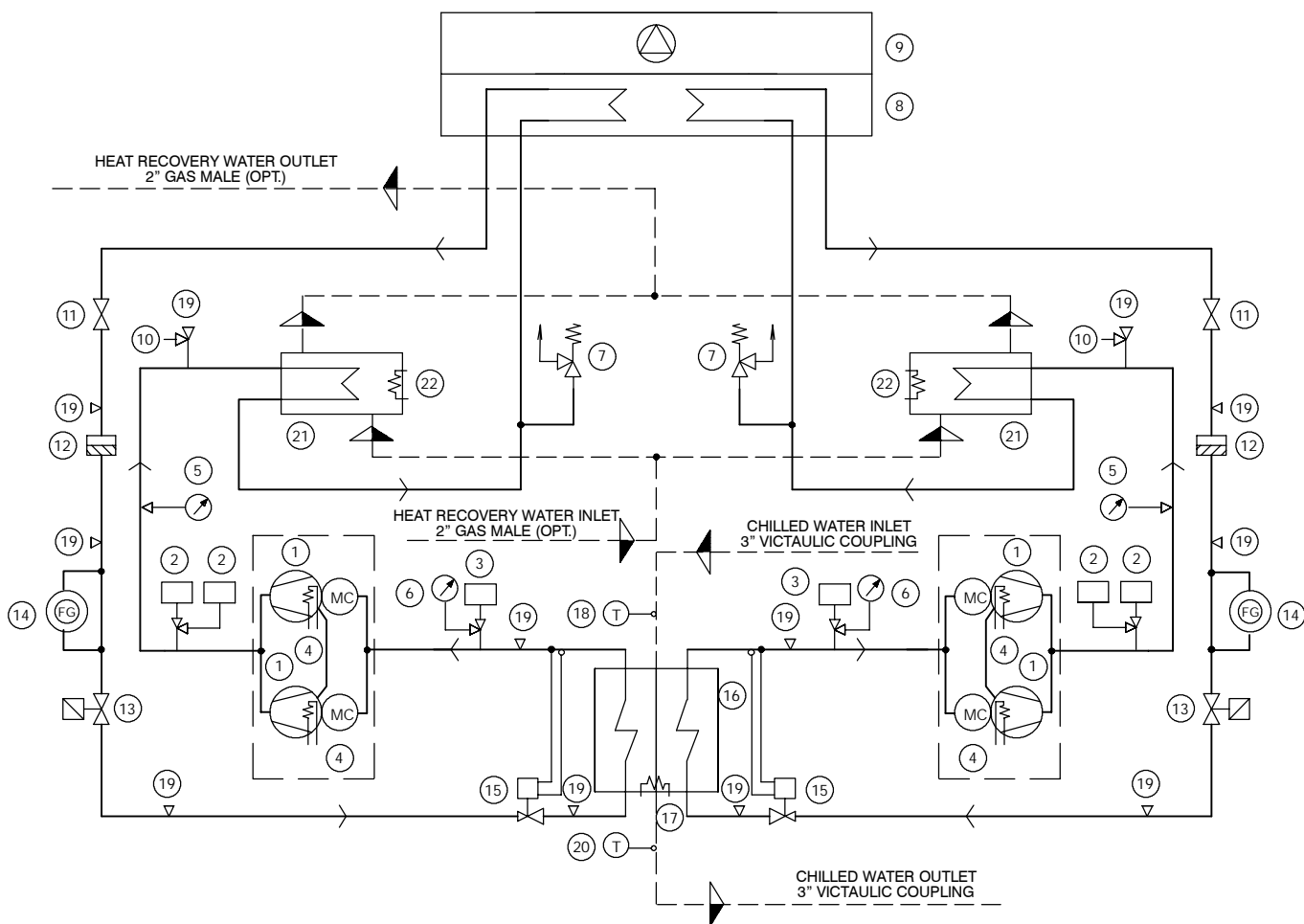

Fig. 8 – Refrigerant circuit (std.) with partial recovery (opt.)
CBH/CLH / SBH/SLH 017–020–023–025–028–030–032
CQH/SQH 017–020–023–025–028–030



Refrigerant components

Pos. Item	Description	Pos. Item	Description
1	Compressor	15	Thermostatic expansion valve
2	High pressure switch (HP)	16	Evaporator
3	Low pressure switch (LP)	17	Antifreeze heater (Opt.)
4	Crankcase heater	18	Control temperature sensor
5	High pressure manometer (Opt.)	19	Charge connection
6	Low pressure manometer (Opt.)	20	Antifreeze sensor
7	Safety valve	21	Partial recovery heat exchanger (Opt.)
8	Condenser	22	Antifreeze heater (Std. with heat recovery)
9	Fans		
10	Pressure transducer (Opt. on Mod. CBH/CLH/CQH without heat recovery)		
11	Shut-off valve		
12	Filter dryer		
13	Shut-off solenoid valve		
14	Sight glass		

Fig. 9 – Refrigerant circuit with total recovery (opt.)
CBH / CLH 017–020–023–025–028–030–032
CQH 017–020–023–025–028–030

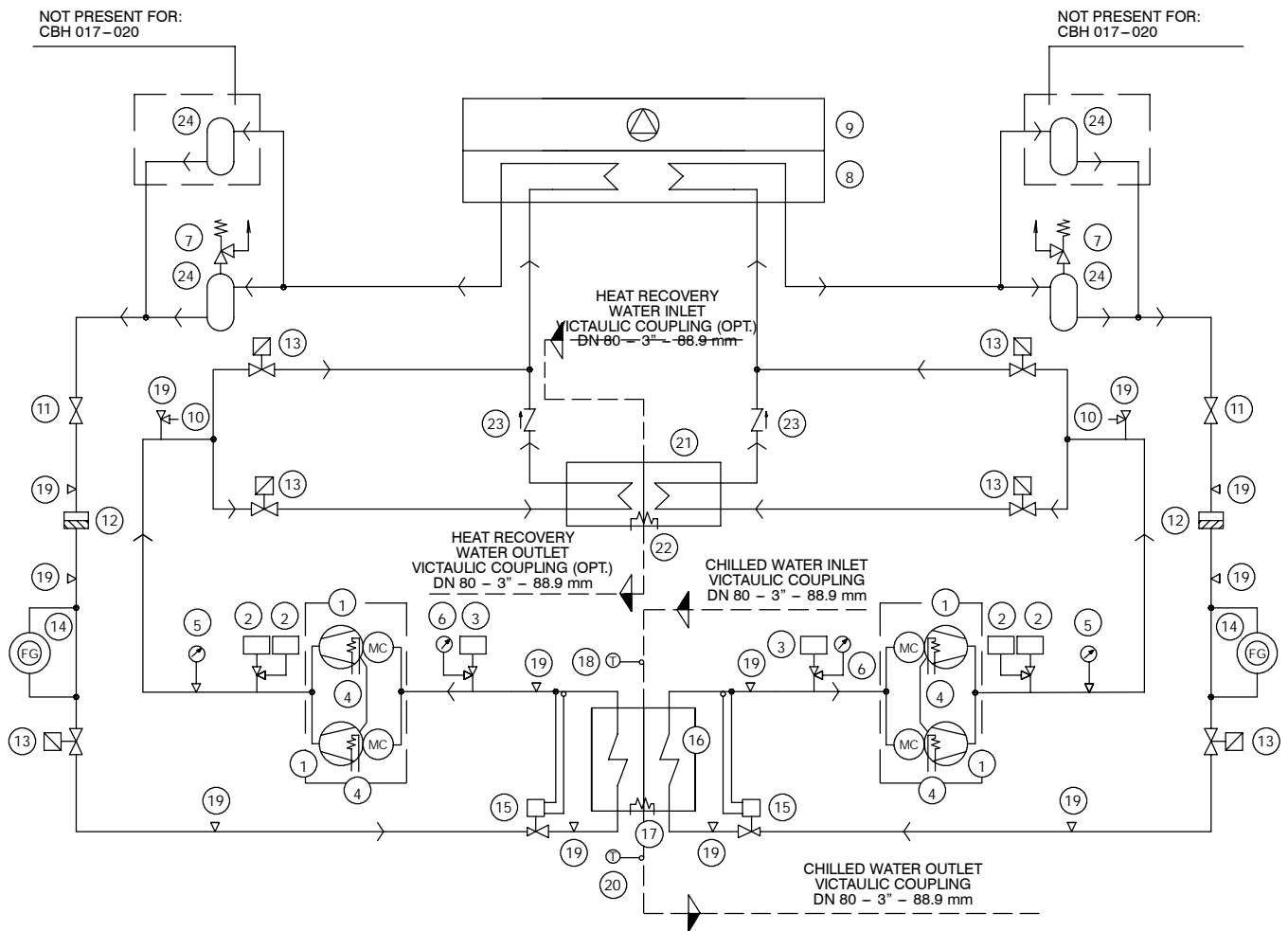

Refrigerant components

Pos. Item	Description	Pos. Item	Description
1	Compressor	15	Thermostatic expansion valve
2	High pressure switch (HP)	16	Evaporator
3	Low pressure switch (LP)	17	Antifreeze heater (Opt.)
4	Crankcase heater	18	Control temperature sensor
5	High pressure manometer (Opt.)	19	Charge connection
6	Low pressure manometer (Opt.)	20	Antifreeze sensor
7	Safety valve	21	Total recovery heat exchanger
8	Condenser	22	Antifreeze heater
9	Fans	23	Non return valve
10	Pressure transducer	24	Liquid receiver
11	Shut-off valve		
12	Filter dryer		
13	Shut-off solenoid valve		
14	Sight glass		

**Fig. 10 – Hydraulic circuit – Chiller CBH/CLH 017–020–023–025–028–030–032
Chiller CQH 017–020–023–025–028–030**

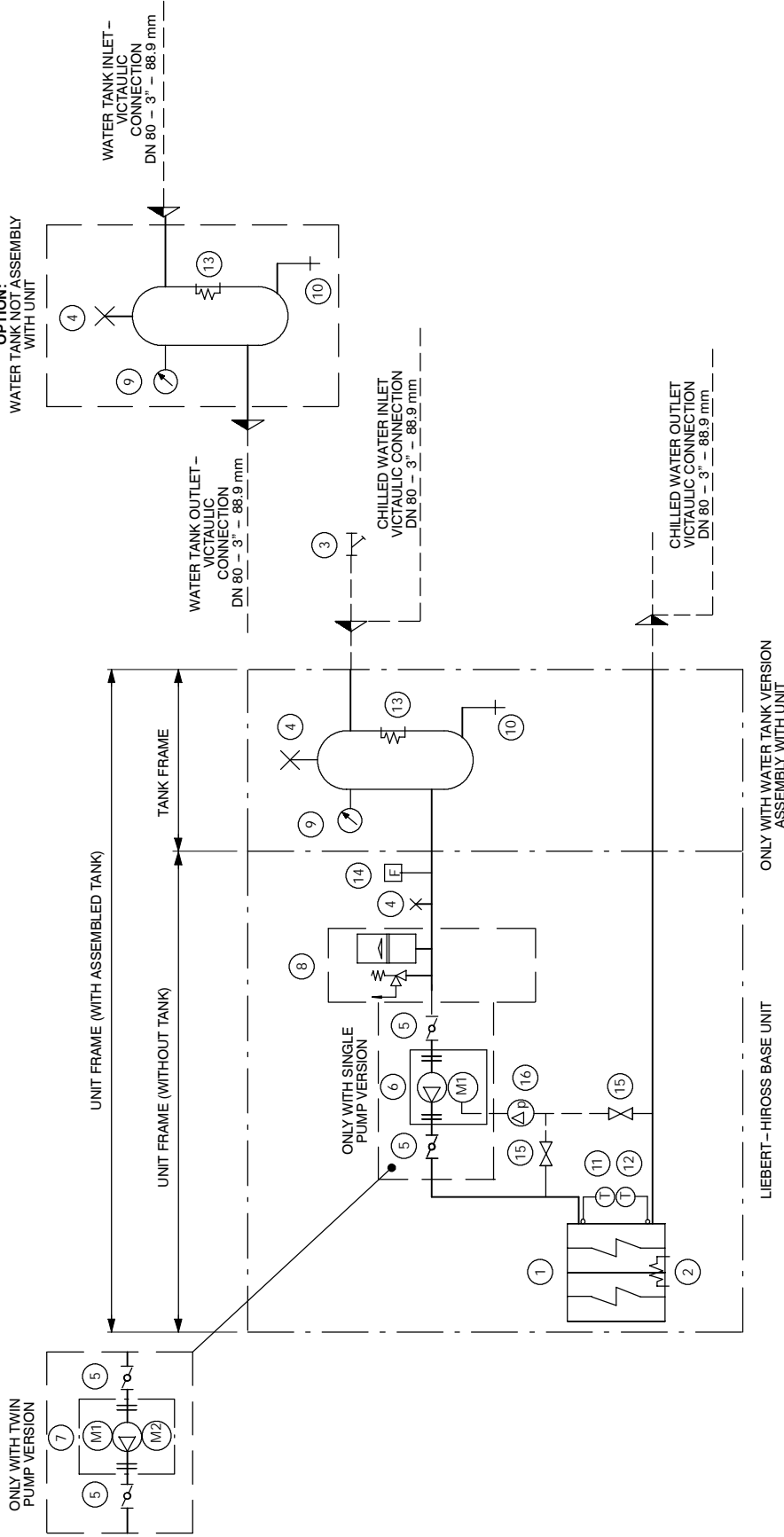

Hydraulic components

Item	Description	Item	Description
1	Evaporator	11	Control temperature sensor
2	Evaporator antifreeze heater (Opt.)	12	Antifreeze temperature sensor
3	Filter (Opt.)	13	Tank antifreeze heater (Opt.)
4	Manual air valve	14	Flow switch (Opt. without pumps)
5	Butterfly valve	15	Service valve with cap
6	Single pump	16	Differential trasducer (only with electronic pump)
7	Twin pump		
8	Expansion tank + Safety valve (Opt.)		
9	Manometer		
10	Discharge valve		

**Fig. 11 – Hydraulic circuit – Superchiller SBH/SLH 017–020–023–025–028–030–032
Superchiller SQH 017–020–023–025–028–030**

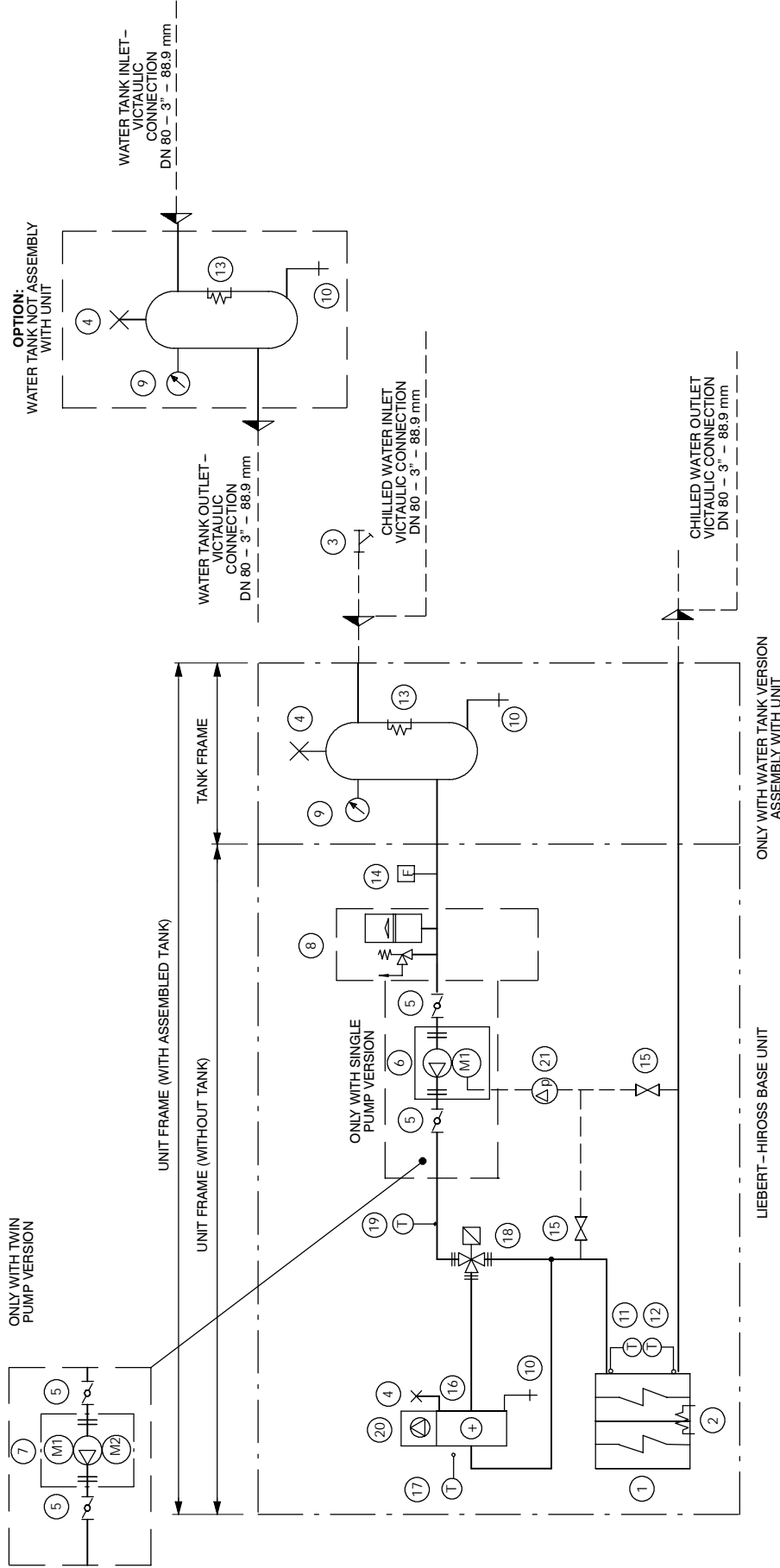

Hydraulic components

Item	Description	Item	Description
1	Evaporator	11	Control temperature sensor
2	Evaporator antifreeze heater (Opt.)	12	Antifreeze temperature sensor
3	Filter (Opt.)	13	Tank antifreeze heater (Opt.)
4	Manual air valve	14	Flow switch (Opt. without pumps)
5	Butterfly valve	15	Service valve with cap
6	Single pump	16	Freecooling coil
7	Twin pump	17	Air temperature sensor
8	Expansion tank + Safety valve (Opt.)	18	3 way valve
9	Service ball valve	19	Control freecooling thermostat sensor
10	Discharge valve	20	Fans
		21	Differential trasducer (only with electronic pump)

Il Fabbricante dichiara che questo prodotto è conforme alle direttive Europee:

The Manufacturer hereby declares that this product conforms to the European Union directives:

Der Hersteller erklärt hiermit, dass dieses Produkt den Anforderungen der Europäischen Richtlinien gerecht wird:

Le Fabricant déclare que ce produit est conforme aux directives Européennes:

El Fabricante declara que este producto es conforme a las directivas Europeas:

O Fabricante declara que este produto está em conformidade com as directivas Europeias:

Tillverkare försäkrar härmed att denna produkt överensstämmer med Europeiska Unionens direktiv:

De Fabrikant verklaart dat dit produkt conform de Europese richtlijnen is:

Vaimistaja vakuuttaa täten, että tämä tuote täyttää seuraavien EU-direktiivien vaatimukset:

Produsent erklærer herved at dette produktet er i samsvar med EU-direktiver:

Fabrikant erklærer herved, at dette produkt opfylder kravene i EU direktiverne:

Ο Κατασκευαστής δηλώνει ότι το παρόν προϊόν είναι κατασκευασμένο σύμφωνα με τις οδηγίες της Ε.Ε.:

98/37/CE; 89/336/CEE; 73/23/CEE; 97/23/CE

**Liebert
HIROSS**



Zona Industriale Tognana
Via Leonardo da Vinci, 16/18
35028 Piove di Sacco (PD)
ITALY

Tel. +39 049 9719111
Telefax +39 049 5841257
Internet : www.liebert-hiross.com



**Liebert HIROSS
is a division of
EMERSON**

Since the Liebert HIROSS Company has a policy of continuous product improvement, it reserves the right to change design and specifications without previous notice.